

Capital Valley Plastics Ltd

Cwmavon Works
Cwmavon
Nr Pontypool
Gwent NP4 8UW

Tel: 01495 772255 Fax: 01495 772251
e-mail: sales@capitalvalleyplastics.com
website: www.capitalvalleyplastics.com



Agrément Certificate

96/3267

Product Sheet 1

CAPITAL VALLEY PLASTICS MEMBRANES

CAPITAL VALLEY PLASTICS DAMP-PROOF MEMBRANE

This Agrément Certificate Product Sheet⁽¹⁾ relates to Capital Valley Plastics Damp-proof Membrane, for use as a low-density polyethylene membrane, for use in solid concrete ground floors which are not subject to hydrostatic pressure, to protect the building against moisture from the ground.

(1) Hereinafter referred to as 'Certificate'.

CERTIFICATION INCLUDES:

- factors relating to compliance with Building Regulations where applicable
- factors relating to additional non-regulatory information where applicable
- independently verified technical specification
- assessment criteria and technical investigations
- design considerations
- installation guidance
- regular surveillance of production
- formal three-yearly review.

KEY FACTORS ASSESSED

Resistance to water and water vapour — the product, including joints, will resist the passage of moisture into the structure (see section 6).

Resistance to puncture — the product has a high resistance to puncture and on a smooth or blinded surface will not be damaged by foot or site traffic (see section 7).

Durability — under normal service conditions, the product will provide an effective barrier to the transmission of moisture for the life of the structure in which it is incorporated (see section 10).

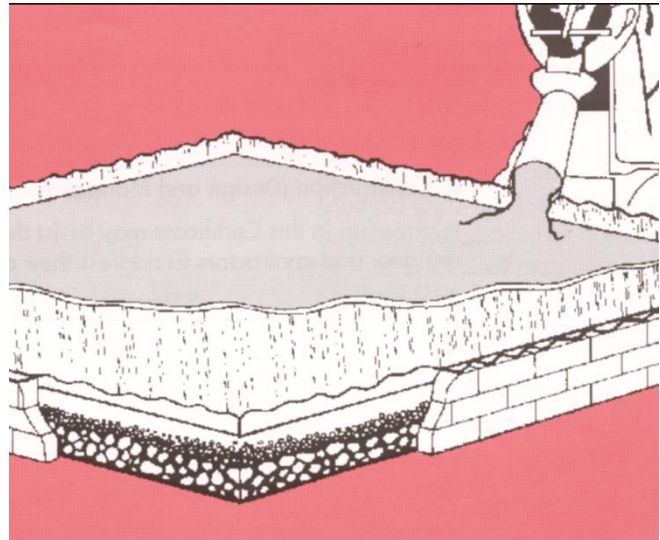

The BBA has awarded this Certificate to the company named above for the product described herein. This product has been assessed by the BBA as being fit for its intended use provided it is installed, used and maintained as set out in this Certificate.

On behalf of the British Board of Agrément

Date of Fourth issue: 12 March 2019

John Albon – Head of Approvals
Construction Products

Originally certificated on 25 July 1996

Claire Curtis-Thomas
Chief Executive

The BBA is a UKAS accredited certification body – Number 113.

The schedule of the current scope of accreditation for product certification is available in pdf format via the UKAS link on the BBA website at www.bbacerts.co.uk
Readers are advised to check the validity and latest issue number of this Agrément Certificate by either referring to the BBA website or contacting the BBA direct.

Any photographs are for illustrative purposes only, do not constitute advice and should not be relied upon.

British Board of Agrément

Bucknalls Lane
Watford
Herts WD25 9BA

©2019

tel: 01923 665300
clientservices@bbacerts.co.uk
www.bbacerts.co.uk

Regulations

In the opinion of the BBA, Capital Valley Plastics Damp-proof Membrane, if installed, used and maintained in accordance with this Certificate, can satisfy or contribute to satisfying the relevant requirements of the following Building Regulations (the presence of a UK map indicates that the subject is related to the Building Regulations in the region or regions of the UK depicted):



The Building Regulations 2010 (England and Wales) (as amended)

Requirement: C2(a)

Comment:

Resistance to moisture

The product, including joints, will enable a floor to satisfy this Requirement. See section 6 of this Certificate.

Regulation: 7

Regulation: 7(1)

Comment:

Materials and workmanship (applicable to Wales only)

Materials and workmanship (applicable to England only)

The product is acceptable. See section 10.1 and the *Installation* part of this Certificate.



The Building (Scotland) Regulations 2004 (as amended)

Regulation: 8(1)

Comment:

Durability, workmanship and fitness of materials

The use of the product satisfies the requirements of this Regulation. See section 10.1 and the *Installation* part of this Certificate.

Regulation: 9

Standard: 3.4

Comment:

Building standards applicable to construction

Moisture from the ground

The product, including joints, will enable a floor to satisfy the requirements of this Standard, with reference to clauses 3.4.1⁽¹⁾⁽²⁾, 3.4.2⁽¹⁾⁽²⁾ and 3.4.4⁽¹⁾⁽²⁾ to 3.4.6⁽¹⁾⁽²⁾. See section 6 of this Certificate.

Standard: 7.1(a)(b)

Comment:

Statement of sustainability

The product can contribute to meeting the relevant Requirements of Regulation 9, Standards 1 to 6 and therefore will contribute to a construction meeting a bronze level of sustainability as defined in this Standard.

Regulation: 12

Comment:

Building standards applicable to conversions

Comments made in relation to the product under Regulation 9, Standards 1 to 6 also apply to this Regulation, with reference to clause 0.12.1⁽¹⁾⁽²⁾ and Schedule 6⁽¹⁾⁽²⁾.

(1) Technical Handbook (Domestic).

(2) Technical Handbook (Non-Domestic).



The Building Regulations (Northern Ireland) 2012 (as amended)

Regulation: 23(a)(i)(iii)(b)(i)

Comment:

Fitness of materials and workmanship

The product is acceptable. See section 10.1 and the *Installation* part of this Certificate.

Regulation: 28(a)

Comment:

Resistance to moisture and weather

The product, including joints, will enable a floor to satisfy the requirements of this Regulation. See section 6 of this Certificate.

Construction (Design and Management) Regulations 2015

Construction (Design and Management) Regulations (Northern Ireland) 2016

Information in this Certificate may assist the client, designer (including Principal Designer) and contractor (including Principal Contractor) to address their obligations under these Regulations.

See section: 1 *Description* (1.2) of this Certificate.

Additional Information

NHBC Standards 2019

In the opinion of the BBA, Capital Valley Plastics Damp-proof Membrane, if installed, used and maintained in accordance with this Certificate, can satisfy or contribute to satisfying the relevant requirements in relation to *NHBC Standards*, Chapters 4.1 *Land quality — managing ground conditions* and 5.1 *Substructure and ground bearing floors*.

CE marking

The Certificate holder has taken the responsibility of CE marking the product in accordance with harmonised European Standard EN 13967 : 2012. An asterisk (*) appearing in this Certificate indicates that data shown are given in the manufacturer's Declaration of Performance.

Technical Specification

1 Description

1.1 Capital Valley Plastics Damp-proof Membrane is a blown film, extruded from 100 % recycled low-density polyethylene (LDPE).

1.2 The nominal characteristics of the membrane are given in Table 1.

Characteristic (unit)	Thickness* (μm)		
	250	300	500
Roll width*(m)	4	4	4
Roll length*(m)	25	25	12.5
Mass per unit area ($\text{g}\cdot\text{m}^{-2}$)	240	280	460
Tensile strength* (N per 50 mm)			
MD	≥ 130	≥ 150	≥ 180
CD	≥ 130	≥ 150	≥ 180
Elongation*(%)			
MD	> 450	> 450	> 300
CD	> 450	> 450	> 300
Water vapour transmission (S_d) value (m)	253.13	284.8	498.6
Watertightness* (2 kPa)	pass	pass	pass
Nail tear* (N)	180	217	324

1.3 Ancillary items for use with the product, and within the scope of this Certificate, include:

- double-sided butyl jointing tape — 50 mm wide for jointing
- girth tape — 75 mm wide polyethylene strip backed with adhesive used for sealing joints.

1.4 Other ancillary items available for use with the product, but outside the scope of this Certificate, include:

- CVP Preformed Top Hat Unit — to seal service entry points to the membrane
- CVP Protection Boards — to protect the membrane against excessive traffic
- CVP Damp-proof Course — flexible damp-proof course (dpc).

2 Manufacture

2.1 The product is manufactured by extrusion.

2.2 As part of the assessment and ongoing surveillance of product quality, the BBA has:

- agreed with the manufacturer the quality control procedures and product testing to be undertaken
- assessed and agreed the quality control operated over batches of incoming materials
- monitored the production process and verified that it is in accordance with the documented process
- evaluated the process for management of nonconformities
- checked that equipment has been properly tested and calibrated
- undertaken to carry out the above measures on a regular basis through a surveillance process, to verify that the specifications and quality control operated by the manufacturer are being maintained.

2.3 The management system of Capital Valley Plastics Ltd has been assessed and registered as meeting the requirements of BS EN ISO 9001 : 2008 by NQA (Certificate 6643).

3 Delivery and site handling

3.1 The product is packaged in rolls either with or without a paper core, and wrapped in individual polythene sleeves bearing the manufacturer's name, product identification and the BBA logo incorporating the number of this Certificate.

3.2 Rolls should be stored under cover and on a flat, level surface.

Assessment and Technical Investigations

The following is a summary of the assessment and technical investigations carried out on Capital Valley Plastics Damp-proof Membrane.

Design Considerations

4 Use

4.1 Capital Valley Plastics Damp-proof Membrane is satisfactory for use in concrete floors which are not subject to hydrostatic pressure, in accordance with the relevant clauses of CP 102 : 1973.

4.2 The product can be installed:

- as an oversite membrane, between a blinded hardcore bed and the base concrete slab
- as a sandwich membrane in a base concrete slab
- between the base concrete slab and the screed.

4.3 The product will remain flexible at the temperatures likely to be experienced in practice.

5 Practicability of installation

The membrane is designed to be installed by a competent builder or contractor experienced with this type of product.

6 Resistance to water and water vapour



6.1 The membrane, including joints, provides an effective barrier to the passage of liquid moisture from the ground.

6.2 When installed in accordance with the following documents, the 300 and 500 μm membranes comply with the minimum sheet thickness detailed in the national Building Regulations. The 250 μm membrane additionally complies with the minimum sheet thickness detailed in the national Building Regulations for Scotland.

7 Resistance to puncture

On smooth or blinded surfaces, the membrane will not be damaged by normal foot or site traffic (eg wheelbarrows) but care must be taken to avoid damage during installation, particularly when handling building materials and equipment over the surface and when placing concrete or screeds.

8 Underfloor heating

When used in accordance with this Certificate, underfloor heating will not adversely affect the membrane under normal operating conditions. However, the Certificate holder's advice should be sought in this respect.

9 Maintenance

As the product is confined and has suitable durability, maintenance is not required. However, any damage occurring during installation must be repaired prior to overlaying with concrete (see section 14) .

10 Durability



10.1 When subjected to normal conditions of use, the membrane will provide an effective barrier to the transmission of moisture for the life of the concrete slab in which it is installed.

10.2 Long periods of exposure to ultraviolet (uv) light will reduce the effectiveness of the membrane. The membrane should be protected from such exposure during storage and installation.

11 Reuse and recyclability

The product comprises polyethylene, which can be recycled.

Installation

12 General

12.1 Installation of Capital Valley Damp-proof Membrane must be in accordance with the Certificate holder's instructions and CP 102 : 1973, clause 11, the relevant clauses of BS 8000-0 : 2014 and BS 8000-4 : 1989, and section 13 of this Certificate.

12.2 The product must be kept clean and free from dirt and grease.

12.3 Unless the base is smooth, a surface blinding of soft sand (or similar material) must be used to prevent puncturing during installation or when the concrete or screed is being placed.

12.4 The product can be installed in all conditions normal to ground-floor slab construction. Where there is a risk of the ground becoming waterlogged, sub-soil drainage must be provided in accordance with CP 102 : 1973.

12.5 The type of floor finish to be used may limit the suitability of a polyethylene damp-proof membrane (dpm). The guidance given in CP 102 : 1973 should be followed.

13 Procedure

13.1 Adjacent sheets must be overlapped by at least 150 mm, bound with double-sided butyl jointing tape and sealed with 75 mm wide girth jointing tape (see Figure 1).

Figure 1 Double-sided butyl tape joint

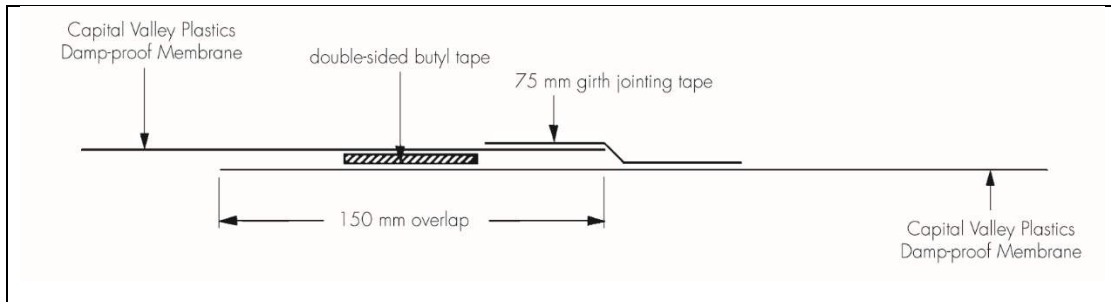

13.2 Alternatively, when it is not possible to keep the sheet dry, a double welted fold should be formed using at least 300 mm of the membrane (see Figure 2). It is essential that the fold is held in position prior to placing the concrete, eg by weighting with bricks.

Figure 2 Double welted fold joint

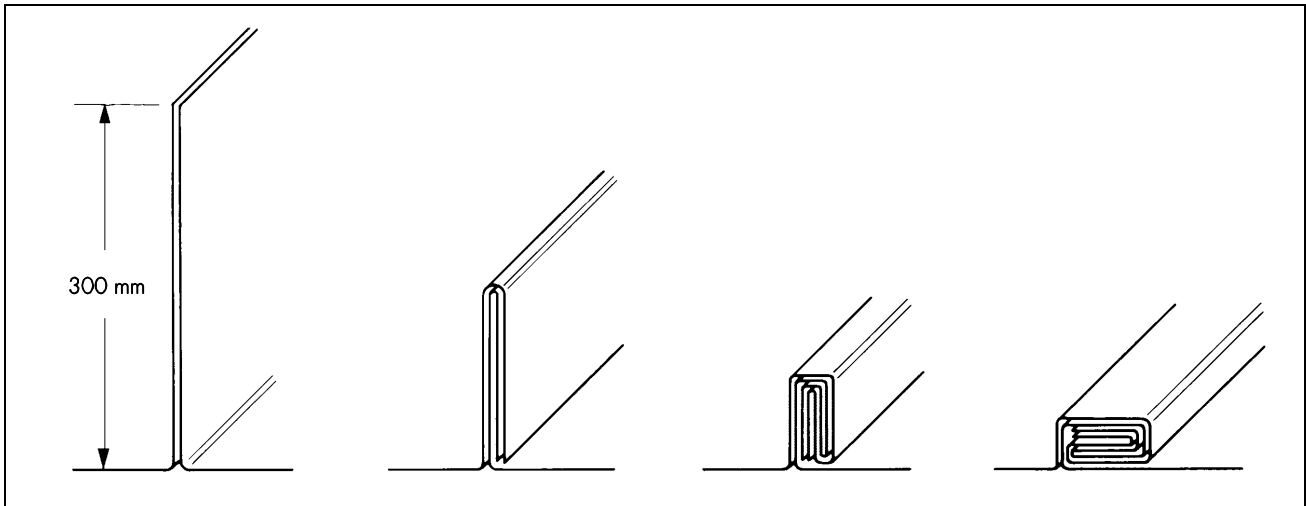

13.3 Perforations or punctures in the sheets must be patched with sheets of identical thickness, lapped at least 150 mm beyond the limits of the puncture and sealed with double-sided pressure sensitive tape.

13.4 The dpm must be continuous with the dpc in the surrounding walls. Where necessary the product must be used as a vertical dpc to link the two.

13.5 The membrane must be covered by a screed or other protective layer as soon as possible after installation. Care must be taken to ensure the membrane is not stretched or displaced when placing the concrete or screed over the membrane. Sufficient allowance must be made to avoid bridging (ie creating areas of unsupported membrane) during screeding operations at details such as internal angles.

14 Repair

Perforations or punctures in the membrane must be patched with Capital Valley Plastics Damp-proof Membrane of identical thickness, lapped at least 150 mm beyond the limits of the puncture and sealed with double-sided sealant tape.

15 Tests

Tests were carried out on the membrane to determine:

- moisture vapour transmission rate
- water vapour resistance
- resistance to impact
- tensile strength and elongation at break
- nail tear resistance
- trouser tear resistance
- low temperature flexibility
- dimensional stability
- strength and effectiveness of joints
- effect of heat and UV ageing on tensile properties
- resistance to static loading.

16 Investigations

The manufacturing process was evaluated, including the methods adopted for quality control, and details were obtained of the quality and composition of the materials used.

Bibliography

BS 8000-0 : 2014 *Workmanship on construction sites — Introduction and general principles*

BS 8000-4 : 1989 *Workmanship on building sites — Code of practice for waterproofing*

EN 13967 : 2012 *Flexible sheets for waterproofing — Plastic and rubber damp proof sheets including plastic and rubber*

BS EN ISO 9001 : 2008 *Quality management systems — Requirements*

CP 102 : 1973 *Code of practice for protection of buildings against water from the ground*

17 Conditions

17.1 This Certificate:

- relates only to the product/system that is named and described on the front page
- is issued only to the company, firm, organisation or person named on the front page – no other company, firm, organisation or person may hold or claim that this Certificate has been issued to them
- is valid only within the UK
- has to be read, considered and used as a whole document – it may be misleading and will be incomplete to be selective
- is copyright of the BBA
- is subject to English Law.

17.2 Publications, documents, specifications, legislation, regulations, standards and the like referenced in this Certificate are those that were current and/or deemed relevant by the BBA at the date of issue or reissue of this Certificate.

17.3 This Certificate will remain valid for an unlimited period provided that the product/system and its manufacture and/or fabrication, including all related and relevant parts and processes thereof:

- are maintained at or above the levels which have been assessed and found to be satisfactory by the BBA
- continue to be checked as and when deemed appropriate by the BBA under arrangements that it will determine
- are reviewed by the BBA as and when it considers appropriate.

17.4 The BBA has used due skill, care and diligence in preparing this Certificate, but no warranty is provided.

17.5 In issuing this Certificate the BBA is not responsible and is excluded from any liability to any company, firm, organisation or person, for any matters arising directly or indirectly from:

- the presence or absence of any patent, intellectual property or similar rights subsisting in the product/system or any other product/system
- the right of the Certificate holder to manufacture, supply, install, maintain or market the product/system
- actual installations of the product/system, including their nature, design, methods, performance, workmanship and maintenance
- any works and constructions in which the product/system is installed, including their nature, design, methods, performance, workmanship and maintenance
- any loss or damage, including personal injury, howsoever caused by the product/system, including its manufacture, supply, installation, use, maintenance and removal
- any claims by the manufacturer relating to CE marking.

17.6 Any information relating to the manufacture, supply, installation, use, maintenance and removal of this product/system which is contained or referred to in this Certificate is the minimum required to be met when the product/system is manufactured, supplied, installed, used, maintained and removed. It does not purport in any way to restate the requirements of the Health and Safety at Work etc. Act 1974, or of any other statutory, common law or other duty which may exist at the date of issue or reissue of this Certificate; nor is conformity with such information to be taken as satisfying the requirements of the 1974 Act or of any statutory, common law or other duty of care.