

## Unilin Insulation UK Ltd

Liscarton Ind Est  
Kells Rd, Navan  
Co Meath C15 NP79  
Ireland

Tel: 0371 222 1033

e-mail: info.ui@unilin.com

website: www.unilininsulation.co.uk



**Agrément Certificate**

**23/6997**

Product Sheet 3 Issue 1

### UNILIN THIN-R INSULATION

### UNILIN THIN-R UNDERFLOOR INSULATION BOARDS (XT/HYF AND XT/PR\_UF)

This Agrément Certificate Product Sheet<sup>(1)</sup> relates to Unilin Thin-R Underfloor Insulation Boards (XT/HYF and XT/PR\_UF), comprising rigid polyisocyanurate (PIR) foam boards with a composite foil-facing on both sides, for use as insulation in ground-bearing or suspended concrete ground floors or between the joists of suspended timber ground floors, in new and existing domestic buildings.

(1) Hereinafter referred to as 'Certificate'.

#### The assessment includes

##### Product factors:

- compliance with Building Regulations
- compliance with additional regulatory or non-regulatory information where applicable
- evaluation against technical specifications
- assessment criteria and technical investigations
- uses and design considerations

##### Process factors:

- compliance with Scheme requirements
- installation, delivery, handling and storage
- production and quality controls
- maintenance and repair

##### Ongoing contractual Scheme elements†:

- regular assessment of production
- formal 3-yearly review

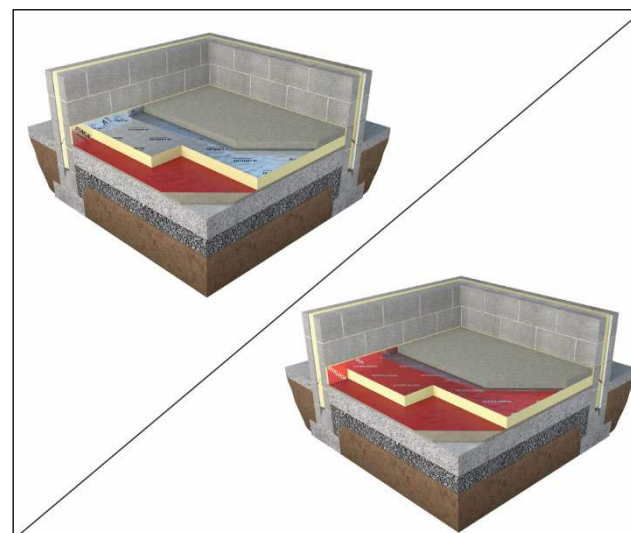

#### KEY FACTORS ASSESSED

- Section 1. Mechanical resistance and stability
- Section 2. Safety in case of fire
- Section 3. Hygiene, health and the environment
- Section 4. Safety and accessibility in use
- Section 5. Protection against noise
- Section 6. Energy economy and heat retention
- Section 7. Sustainable use of natural resources
- Section 8. Durability

The BBA has awarded this Certificate to the company named above for the products described herein. These products have been assessed by the BBA as being fit for their intended use provided they are installed, used and maintained as set out in this Certificate.

On behalf of the British Board of Agrément

Date of issue: 30 August 2023

Hardy Giesler  
Chief Executive Officer

Certificate amended on 1 November 2023 to remove Table 5 Emissivity.

*This BBA Agrément Certificate is issued under the BBA's Inspection Body accreditation to ISO/IEC 17020. Sections marked with † are not issued under accreditation.*

*The BBA is a UKAS accredited Inspection Body (No. 4345), Certification Body (No. 0113) and Testing Laboratory (No. 0357).*

*Readers MUST check that this is the latest issue of this Agrément Certificate by either referring to the BBA website or contacting the BBA directly.*

*The Certificate should be read in full as it may be misleading to read clauses in isolation.*

*Any photographs are for illustrative purposes only, do not constitute advice and should not be relied upon.*

#### British Board of Agrément

1<sup>st</sup> Floor, Building 3, Hatters Lane  
Croxley Park, Watford  
Herts WD18 8YG

©2023

tel: 01923 665300  
clientservices@bbacerts.co.uk  
www.bbacerts.co.uk

## SUMMARY OF ASSESSMENT AND COMPLIANCE

This section provides a summary of the assessment conclusions; readers should refer to the later sections of this Certificate for information about the assessments carried out.

### Compliance with Regulations

Having assessed the key factors, the opinion of the BBA is that Unilin Thin-R Underfloor Insulation Boards (XT/HYF and XT/PR\_UF), if installed, used and maintained in accordance with this Certificate, can satisfy or contribute to satisfying the relevant requirements of the following Building Regulations:



#### The Building Regulations 2010 (England and Wales) (as amended)

|                     |                 |   |
|---------------------|-----------------|---|
| <b>Requirement:</b> | <b>A1</b>       | <b>Loading</b>  |
| Comment:            |                 | The products can contribute to satisfying this Requirement. See section 1 of this Certificate.  |
| <b>Requirement:</b> | <b>C2(c)</b>    | <b>Resistance to moisture</b>   |
| Comment:            |                 | The products can contribute to satisfying this Requirement. See section 3 of this Certificate.  |
| <b>Requirement:</b> | <b>L1(a)(i)</b> | <b>Conservation of fuel and power</b>   |
| Comment:            |                 | The products can contribute to satisfying this Requirement. See section 6 of this Certificate.  |
| <b>Regulation:</b>  | <b>7(1)</b>     | <b>Materials and workmanship</b>  |
| Comment:            |                 | The products are acceptable. See sections 8 and 9 of this Certificate.                          |
| <b>Regulation:</b>  | <b>25B</b>      | <b>Nearly zero-energy requirements for new buildings</b>  |
| <b>Regulation:</b>  | <b>26</b>       | <b>CO<sub>2</sub> emission rates for new buildings</b>  |
| <b>Regulation:</b>  | <b>26A</b>      | <b>Fabric energy efficiency rates for new dwellings (applicable to England only)</b>            |
| <b>Regulation:</b>  | <b>26A</b>      | <b>Primary energy rates for new buildings (applicable to Wales only)</b>                        |
| <b>Regulation:</b>  | <b>26B</b>      | <b>Fabric performance values for new dwellings (applicable to Wales only)</b>                   |
| <b>Regulation:</b>  | <b>26C</b>      | <b>Target primary energy rates for new buildings (applicable to England only)</b>               |
| <b>Regulation:</b>  | <b>26C</b>      | <b>Energy efficiency rating (applicable to Wales only)</b>                                      |
| Comment:            |                 | The products can contribute to satisfying these Regulations. See section 6 of this Certificate. |



#### The Building (Scotland) Regulations 2004 (as amended)

|                    |                     |   |
|--------------------|---------------------|---|
| <b>Regulation:</b> | <b>8(1)</b>         | <b>Fitness and durability of materials and workmanship</b>  |
| Comment:           |                     | The products are acceptable. See sections 8 and 9 of this Certificate.  |
| <b>Regulation:</b> | <b>9</b>            | <b>Building standards – construction</b>  |
| Standard:          | <b>1.1(b)</b>       | <b>Structure</b>  |
| Comment:           |                     | The products can contribute to satisfying this Standard, with reference to clause 1.1.2 <sup>(1)</sup> . See section 1 of this Certificate.   |
| Standard:          | <b>3.15</b>         | <b>Condensation</b>   |
| Comment:           |                     | The products can contribute to satisfying this Standard, with reference to clauses 3.15.1 <sup>(1)</sup> , 3.15.4 <sup>(1)</sup> and 3.15.5 <sup>(1)</sup> . See section 3 of this Certificate. |
| Standard:          | <b>6.1(b)(c)(d)</b> | <b>Energy demand and carbon dioxide emissions</b>   |
| Comment:           |                     | The products can contribute to satisfying this Standard with reference to clause 6.1.1 <sup>(1)</sup> . See section 6 of this Certificate.  |

|                         |           |  |
|-------------------------|-----------|--|
| Standard:<br>Comment:   | 6.2       | Building insulation envelope<br>The products can contribute to satisfying these Standards, with reference to clauses, or parts of clauses, 6.2.1 <sup>(1)</sup> , 6.2.3 <sup>(1)</sup> , 6.2.6 <sup>(1)</sup> , 6.2.7 <sup>(1)</sup> , 6.2.8 <sup>(1)</sup> , 6.2.9 <sup>(1)</sup> , 6.2.10 <sup>(1)</sup> , 6.2.11 <sup>(1)</sup> and 6.2.12 <sup>(1)</sup> . See section 6 of this Certificate.  |
| Standard:<br>Comment:   | 7.1(a)(b) | Statement of sustainability<br>The products can contribute to satisfying the relevant requirements of Regulation 9, Standards 1 to 6, and therefore will contribute to a construction meeting at least a bronze level of sustainability as defined in this Standard. In addition, the products can contribute to a construction meeting a higher level of sustainability as defined in this Standard, with reference to clauses 7.1.2 <sup>(1)</sup> , 7.1.4 <sup>(1)</sup> , 7.1.6 <sup>(1)</sup> and 7.1.7 <sup>(1)</sup> . See section 6 of this Certificate. |
| Regulation:<br>Comment: | 12        | <b>Building standards – conversions</b><br>Comments in relation to these products under Regulation 9, Standards 1 to 6, also apply to this Regulation, with reference to clause 0.12.1 <sup>(1)</sup> and Schedule 6 <sup>(1)</sup> .  |

(1) Technical Handbook (Domestic).



## The Building Regulations (Northern Ireland) 2012 (as amended)

|  |                                      |  |
|--|--------------------------------------|--|
| Regulation:<br>Comment:  | 23(1)(a)(i)<br>(iii)(b)(i)(ii)       | <b>Fitness of materials and workmanship</b><br>The products are acceptable. See sections 8 and 9 of this Certificate.  |
| Regulation:<br>Comment:  | 29                                   | <b>Condensation</b><br>The products can contribute to satisfying this Regulation. See section 3 of this Certificate.   |
| Regulation:<br>Comment:  | 30                                   | <b>Stability</b><br>The products can contribute to satisfying this Regulation. See section 1 of this Certificate.  |
| Regulation:<br>Regulation:<br>Regulation:<br>Regulation:<br>Comment: | 39(a)(i)<br>40(2)<br>43(1)(2)<br>43B | <b>Conservation measures</b><br><b>Target carbon dioxide emission rate</b><br><b>Renovation of thermal elements</b><br><b>Nearly zero-energy requirements for new buildings</b><br>The products can contribute to satisfying these Regulations. See section 6 of this Certificate. |

## Additional Information

### NHBC Standards 2023

In the opinion of the BBA, Unilin Thin-R Underfloor Insulation Boards (XT/HYF and XT/PR\_UF), if installed, used and maintained in accordance with this Certificate, can satisfy or contribute to satisfying the relevant requirements in relation to *NHBC Standards*, Chapters 5.1 *Substructure and ground bearing floors* and 5.2 *Suspended ground floors*.

## Fulfilment of Requirements

The BBA has judged Unilin Thin-R Underfloor Insulation Boards (XT/HYF and XT/PR\_UF) to be satisfactory for use as described in this Certificate. The products have been assessed for use as insulation in ground-bearing or suspended concrete ground-floors or timber ground-floors, in new and existing domestic buildings.

## ASSESSMENT

### Product description and intended use

The Certificate holder provided the following description for the products under assessment. Unilin Thin-R Underfloor Insulation Boards (XT/HYF and XT/PR\_UF) comprise rigid polyisocyanurate (PIR) foam boards with composite foil-facings. The boards have the nominal characteristics shown in Table 1.

Table 1 Nominal characteristics

| Characteristic   | Product                 |  |
|--|-------------------------|--|
|  | XT/HYF                  | XT/PR_UF   |
| Length   | 2400 mm                 | 2400 mm  |
| Width  | 1200 mm                 | 1200 mm  |
| Thickness  | 75, 100, 125 and 150 mm | 25, 30, 40, 50, 60, 70, 75, 90, 100, 110, 120, 125, 140 and 150 mm |
| Flatness (board length ≤ 2.5 m; area > 0.75 m <sup>2</sup> ) | Deviation ≤ 10 mm       | Deviation ≤ 10 mm  |
| Edge profile   | Square                  | Square   |

The products are intended for use as floor insulation in new and existing domestic buildings:

- ground-supported concrete floors
- suspended concrete ground floors
- between the joists of suspended timber ground floors
- on suitably designed beam-and-block floors incorporating Type R2 semi-resisting or resisting blocks to BS EN 15037-2 : 2009 and self-bearing beams to BS EN 15037-1 : 2008.

#### Ancillary items

The Certificate holder recommends the following ancillary items for use with the products, but these materials have not been assessed by the BBA and are outside the scope of this Certificate. The overlay to the products should be:

- an air and vapour control layer (AVCL) where necessary (see section 3) and,
- a cement-based floor screed of minimum 65 mm<sup>(1)</sup> thickness, laid in accordance with the relevant clauses of BS 8204-1 : 2003 and/or BS 8204-2 : 2003, and BS 8000-9 : 2003 or,
- wood-based floor [eg, tongue-and-groove plywood to BS EN 636 : 2012, flooring grade particle board (Type P4 or P7) to BS EN 312 : 2010 or oriented strand board (Type OSB/3 to OSB/4) to BS EN 300 : 2006], of a thickness to be determined by a suitably qualified and experienced individual, and installed in accordance with PD CEN/TR 12872 : 2014 and BS EN 12871 : 2013 or,
- a concrete slab to BS EN 1992-1-1 : 2004.

(1) The NHBC only accept ground-supported floor slabs with at least 100 mm thick concrete including a monolithic screed.

### Product assessment – key factors

The products were assessed for the following key factors, and the outcome of the assessments is shown below. Conclusions relating to the Building Regulations apply to the whole of the UK unless otherwise stated.

## 1 Mechanical resistance and stability

Data were assessed for the following characteristics.

### 1.1 Floor loading

1.1.1 The products were tested for compressive strength and the results are given in Table 2.

**Table 2 Compressive strength**

| Product assessed   | Assessment method | Requirement   | Result  |
|--|-------------------|---|---------|
| Unilin Thin-R Underfloor Insulation Boards (XT/HYF and XT/PR_UF) | BS EN 826 : 2013  | Declared minimum compressive strength of the product at 10% deformation | 150 kPa |

1.1.2 On the basis of data assessed, the products are suitable for the occupancies defined in this Certificate when covered with a suitable floor overlay and are capable of resisting a uniformly distributed load of  $1.5 \text{ kN}\cdot\text{m}^{-2}$  or a concentrated load of 2 kN for category A1 and A2 (domestic) situations as defined in the UK National Annex to BS EN 1991-1-1 : 2002, Table NA.2. Further assessment by a suitably competent and experienced individual is necessary in the case of duty walkways and floors subject to physical activities.

1.1.3 The performance of a specific floor construction will depend on the insulation properties and type of floor overlay used (including thickness and strength). When the products are used under a concrete slab, resistance to concentrated and distributed loads is a function of the slab specification. Further guidance on the suitability of floor overlays can be found in BS EN 13810-1 : 2002, DD CEN/TS 13810-2 : 2003, BS 8204-1 : 2003 and BS EN 312 : 2010, and from the flooring manufacturer, although the latter is outside of the scope of this Certificate.

## 2 Safety in case of fire

Data were assessed for the following characteristics.

### 2.1 Reaction to fire

2.1.1 The Certificate holder has not declared a reaction to fire classification to BS EN 13501-1 : 2018 for the products.

2.1.2 Where an intermediate floor incorporating the products is required to achieve a period of fire resistance, its performance should be confirmed by a suitably qualified and experienced individual or by a test from a suitably accredited laboratory.

## 3 Hygiene, health and the environment

Data were assessed for the following characteristics.

### 3.1 Water vapour permeability

The products were tested for water vapour permeability and the results are given in Table 3.

**Table 3 Water vapour resistance/resistivity**

| Material             | Assessment method      | Requirement    | Result  |
|----------------------|------------------------|----------------|---|
| PIR insulation core  | BS EN ISO 10456 : 2007 | Declared value | $300 \text{ MN}\cdot\text{s}\cdot\text{g}^{-1}\cdot\text{m}^{-1}$ |
| Composite foil facer | BS 3177 : 1959         | Value achieved | $7000 \text{ MN}\cdot\text{s}\cdot\text{g}^{-1}$                  |

### 3.2 Condensation

3.2.1 The BBA has assessed the products for the risk of interstitial condensation, and the following factors must be implemented:

3.2.1.1 When the products are used on a ground-bearing floor or a suspended concrete floor, an AVCL must be installed on the warm side of the insulation to inhibit the risk of interstitial condensation, unless a risk assessment shows this is not necessary.

3.2.1.2 Voids below suspended timber ground floors must be ventilated. Ventilation may be achieved by installing vents not less than  $1500 \text{ mm}^2\cdot\text{m}^{-1}$  run of external wall or  $500 \text{ mm}^2\cdot\text{m}^{-2}$  of floor area, whichever is the greater. Ventilation openings must be arranged to prevent the ingress of rain, snow, birds and small mammals, and the risk of subsequent blockage by other building operations.

## 4 Safety and accessibility in use

Not applicable.

## 5 Protection against noise

Not applicable.

## 6 Energy economy and heat retention

Data were assessed for the following characteristics.

### 6.1 Thermal conductivity

The products were tested for thermal conductivity and the results are given in Table 4.

*Table 4 Thermal conductivity*

| Product assessed                  | Assessment method                             | Requirement                    | Result                                   |
|-----------------------------------|---|--------------------------------|--|
| Thin-R (XT/PR_UF)<br>PIR board    | Thermal conductivity to<br>BS EN 13165 : 2012 | Declared value ( $\lambda_D$ ) | 0.022 W·m <sup>-1</sup> ·K <sup>-1</sup> |
| Thin-R Plus (XT/HYF)<br>PIR board | Thermal conductivity to<br>BS EN 13165 : 2012 | Declared value ( $\lambda_D$ ) | 0.021 W·m <sup>-1</sup> ·K <sup>-1</sup> |

### 6.2 Conservation of fuel and power

6.2.1 Example U-values are given in Tables 5 and 6.

*Table 5 Example U values (XT/PR\_UF) – ground-floor construction*

| Floor Type   | Target U value<br>(W·m <sup>-2</sup> ·K <sup>-1</sup> ) | Unilin Thin-R Underfloor Insulation (XT/PR_UF)<br>Insulation thickness (mm) |                    |                    |                    |                    |
|--|---|---|--------------------|--------------------|--------------------|--------------------|
|  |   | P/A ratio   |                    |                    |                    |                    |
|  |   | 0.2   | 0.4                | 0.6                | 0.8                | 1.0                |
| Ground-bearing<br>concrete floor <sup>(1)(4)</sup>   | 0.11  | 120   | 150                | 160 <sup>(5)</sup> | 165 <sup>(5)</sup> | 170 <sup>(5)</sup> |
|  | 0.12  | 110   | 140                | 150                | 150                | 155 <sup>(5)</sup> |
|  | 0.13  | 100   | 120                | 140                | 140                | 140                |
|  | 0.15  | 75  | 100                | 110                | 120                | 120                |
|  | 0.18  | 50  | 75                 | 90                 | 100                | 100                |
|  | 0.22  | 30  | 60                 | 70                 | 75                 | 75                 |
|  | 0.25  | 25  | 50                 | 60                 | 60                 | 70                 |
| Suspended concrete<br>ground-floor <sup>(2)(4)</sup> | 0.11  | 140   | 155 <sup>(5)</sup> | 165 <sup>(5)</sup> | 165 <sup>(5)</sup> | 170 <sup>(5)</sup> |
|  | 0.12  | 120   | 140                | 150                | 150                | 155 <sup>(5)</sup> |
|  | 0.13  | 110   | 140                | 140                | 140                | 140                |
|  | 0.15  | 90  | 110                | 120                | 120                | 120                |
|  | 0.18  | 70  | 90                 | 90                 | 100                | 100                |
|  | 0.22  | 50  | 60                 | 70                 | 75                 | 75                 |
|  | 0.25  | 30  | 50                 | 60                 | 60                 | 70                 |
| Suspended timber<br>ground-floor <sup>(3)</sup>      | 0.11  | 205 <sup>(5)</sup>  | 230 <sup>(5)</sup> | 250 <sup>(5)</sup> | 250 <sup>(5)</sup> | 250 <sup>(5)</sup> |
|  | 0.12  | 180 <sup>(5)</sup>  | 210 <sup>(5)</sup> | 220 <sup>(5)</sup> | 225 <sup>(5)</sup> | 230 <sup>(5)</sup> |
|  | 0.13  | 160 <sup>(5)</sup>  | 190 <sup>(5)</sup> | 200 <sup>(5)</sup> | 205 <sup>(5)</sup> | 210 <sup>(5)</sup> |
|  | 0.15  | 125   | 155 <sup>(5)</sup> | 165 <sup>(5)</sup> | 170 <sup>(5)</sup> | 175 <sup>(5)</sup> |
|  | 0.18  | 90  | 120                | 140                | 140                | 140                |
|  | 0.22  | 60  | 90                 | 100                | 110                | 110                |
|  | 0.25  | 50  | 70                 | 80                 | 90                 | 90                 |

- (1) Ground-bearing concrete floor construction (Unilin Thin-R Underfloor Insulation (XT/PR\_UF) on top of slab, under screed finish) 65 mm concrete screed ( $\lambda = 1.15 \text{ W}\cdot\text{m}^{-1}\cdot\text{K}^{-1}$ ), polyethylene separating layer, Unilin Thin-R Underfloor Insulation (XT/PR\_UF), damp-proof membrane (DPM), 100 mm concrete oversite, 150 mm sand-blinded hardcore, ground ( $\lambda = 1.5 \text{ W}\cdot\text{m}^{-1}\cdot\text{K}^{-1}$ ).
- (2) Suspended concrete ground-floor construction (Unilin Thin-R Underfloor Insulation (XT/PR\_UF) on top of beam and block, below screed finish) – 65 mm concrete screed  $\lambda = 1.15 \text{ W}\cdot\text{m}^{-1}\cdot\text{K}^{-1}$ , polyethylene separating layer, Unilin Thin-R Underfloor Insulation (XT/PR\_UF), beam and block floor (12%) Beam ( $\lambda = 2.00 \text{ W}\cdot\text{m}^{-1}\cdot\text{K}^{-1}$ ), dense block infill ( $\lambda = 1.13 \text{ W}\cdot\text{m}^{-1}\cdot\text{K}^{-1}$ ), ventilated void.
- (3) Suspended timber ground-floor construction (Unilin Thin-R Underfloor Insulation (XT/PR\_UF) between floor joists) – floor deck based on 22 mm chipboard ( $\lambda = 0.13 \text{ W}\cdot\text{m}^{-1}\cdot\text{K}^{-1}$ ), Unilin Thin-R Underfloor Insulation (XT/PR\_UF) (89%) between 47 mm wide joists at 400 mm centres. The depth of the joists = 100 to 200 mm depending on the depth of insulation between timber ( $\lambda = 0.13 \text{ W}\cdot\text{m}^{-1}\cdot\text{K}^{-1}$ ) floor joists (11%) based on BRE Report BR 443 : 2019 (38 mm wide nogging every 3 m).
- (4) 25 mm edge insulation of Unilin Thin-R Underfloor Insulation (XT/PR\_UF), 65 mm deep.
- (5) Thickness created by using two boards.

**Table 6 Example U values (XT/HYF) – ground-floor construction**

| Floor Type   | Target U value<br>( $\text{W}\cdot\text{m}^{-2}\cdot\text{K}^{-1}$ ) | Unilin Thin-R Plus Underfloor Insulation (XT/HYF)<br>Insulation thickness (mm) |                       |                       |                       |                       |
|--|--|--|-----------------------|-----------------------|-----------------------|-----------------------|
|  |  | P/A ratio  |                       |                       |                       |                       |
|  |  | 0.2  | 0.4                   | 0.6                   | 0.8                   | 1.0                   |
| Ground-bearing<br>concrete floor <sup>(1)(4)</sup>   | 0.11   | 125 <sup>(6)</sup>   | 150                   | 175 <sup>(5)(6)</sup> | 175 <sup>(5)(6)</sup> | 175 <sup>(5)(6)</sup> |
|  | 0.12   | 100  | 150                   | 150                   | 150                   | 150                   |
|  | 0.13   | 100  | 125 <sup>(6)</sup>    | 125                   | 150 <sup>(6)</sup>    | 150 <sup>(6)</sup>    |
|  | 0.15   | 75   | 100                   | 125 <sup>(6)</sup>    | 125 <sup>(6)</sup>    | 125 <sup>(6)</sup>    |
|  | 0.18   | 75 <sup>(6)</sup>  | 75                    | 100 <sup>(6)</sup>    | 100                   | 100                   |
|  | 0.22   | 75 <sup>(6)</sup>  | 75 <sup>(6)</sup>     | 75 <sup>(6)</sup>     | 75                    | 75                    |
|  | 0.25   | 75 <sup>(6)</sup>  | 75 <sup>(6)</sup>     | 75 <sup>(6)</sup>     | 75 <sup>(6)</sup>     | 75 <sup>(6)</sup>     |
| Suspended concrete<br>ground-floor <sup>(2)(4)</sup> | 0.11   | 150 <sup>(6)</sup>   | 150 <sup>(6)</sup>    | 175 <sup>(5)(6)</sup> | 175 <sup>(5)(6)</sup> | 175 <sup>(5)(6)</sup> |
|  | 0.12   | 125 <sup>(6)</sup>   | 150 <sup>(6)</sup>    | 150                   | 150                   | 150                   |
|  | 0.13   | 125 <sup>(6)</sup>   | 125                   | 150 <sup>(6)</sup>    | 150 <sup>(6)</sup>    | 150 <sup>(6)</sup>    |
|  | 0.15   | 100 <sup>(6)</sup>   | 100                   | 125 <sup>(6)</sup>    | 125 <sup>(6)</sup>    | 125 <sup>(6)</sup>    |
|  | 0.18   | 75 <sup>(6)</sup>  | 100 <sup>(6)</sup>    | 100 <sup>(6)</sup>    | 100                   | 100                   |
|  | 0.22   | 75 <sup>(6)</sup>  | 75 <sup>(6)</sup>     | 75 <sup>(6)</sup>     | 75                    | 75                    |
|  | 0.25   | 75 <sup>(6)</sup>  | 75 <sup>(6)</sup>     | 75 <sup>(6)</sup>     | 75 <sup>(6)</sup>     | 75 <sup>(6)</sup>     |
| Suspended timber<br>ground-floor <sup>(3)</sup>      | 0.11   | 200 <sup>(5)</sup>   | 225 <sup>(5)</sup>    | 250 <sup>(5)</sup>    | 250 <sup>(5)</sup>    | 250 <sup>(5)</sup>    |
|  | 0.12   | 175 <sup>(5)</sup>   | 225 <sup>(5)(6)</sup> | 225 <sup>(5)(6)</sup> | 225 <sup>(5)</sup>    | 225 <sup>(5)</sup>    |
|  | 0.13   | 155 <sup>(5)</sup>   | 200 <sup>(5)(6)</sup> | 200 <sup>(5)</sup>    | 200 <sup>(5)</sup>    | 225 <sup>(5)(6)</sup> |
|  | 0.15   | 125  | 150                   | 175 <sup>(5)(6)</sup> | 175 <sup>(5)(6)</sup> | 175 <sup>(5)</sup>    |
|  | 0.18   | 100 <sup>(6)</sup>   | 125 <sup>(6)</sup>    | 150 <sup>(6)</sup>    | 150 <sup>(6)</sup>    | 150 <sup>(6)</sup>    |
|  | 0.22   | 75 <sup>(6)</sup>  | 100 <sup>(6)</sup>    | 100                   | 100                   | 125 <sup>(6)</sup>    |
|  | 0.25   | 75 <sup>(6)</sup>  | 75 <sup>(6)</sup>     | 100 <sup>(6)</sup>    | 100 <sup>(6)</sup>    | 100 <sup>(6)</sup>    |

- (1) Ground-bearing concrete floor construction (Unilin Thin-R Plus Underfloor Insulation (XT/HYF) on top of slab, under screed finish) 65 mm concrete screed ( $\lambda = 1.15 \text{ W}\cdot\text{m}^{-1}\cdot\text{K}^{-1}$ ), polyethylene separating layer, Unilin Thin-R Plus Underfloor Insulation (XT/HYF), DPM, 100 mm concrete oversite, 150 mm sand-blinded hardcore, ground ( $\lambda = 1.5 \text{ W}\cdot\text{m}^{-1}\cdot\text{K}^{-1}$ ).
- (2) Suspended concrete ground-floor construction (Unilin Thin-R Plus Underfloor Insulation (XT/HYF) on top of beam and block, below screed finish) – 65 mm concrete screed  $\lambda = 1.15 \text{ W}\cdot\text{m}^{-1}\cdot\text{K}^{-1}$ , polyethylene separating layer, Unilin Thin-R Plus Underfloor Insulation (XT/HYF), beam and block floor (12%) Beam ( $\lambda = 2.00 \text{ W}\cdot\text{m}^{-1}\cdot\text{K}^{-1}$ ), dense block infill ( $\lambda = 1.13 \text{ W}\cdot\text{m}^{-1}\cdot\text{K}^{-1}$ ), ventilated void.
- (3) Suspended timber ground-floor construction (Unilin Thin-R Plus Underfloor Insulation (XT/HYF) between floor joists) – floor deck based on 22 mm chipboard ( $\lambda = 0.13 \text{ W}\cdot\text{m}^{-1}\cdot\text{K}^{-1}$ ), Unilin Thin-R Plus Underfloor Insulation (XT/HYF) (89%) between 47 mm wide joists at 400 mm centres. The depth of the joists = 100 to 200 mm depending on the depth of insulation between timber ( $\lambda = 0.13 \text{ W}\cdot\text{m}^{-1}\cdot\text{K}^{-1}$ ) floor joists (11%) based on BRE Report BR 443 : 2019 (38 mm wide nogging every 3 m).
- (4) 25 mm edge insulation of Unilin Thin-R Plus Underfloor Insulation (XT/HYF), 65 mm deep.
- (5) Thickness created by using two boards.
- (6) Nearest available thickness.

6.2.2 The U value of a completed floor will depend on the insulation thickness, the perimeter/area ratio, and the floor type.

6.2.3 The products can contribute towards a floor construction satisfying the national Building Regulations in respect of energy economy and heat retention.

## 7 Sustainable use of natural resources

Not applicable.

## 8 Durability

8.1 The potential mechanisms for degradation and the known performance characteristics of the materials in the products were assessed.

8.2 Data were assessed for the characteristics shown in Table 7.

| Product assessed                                       | Assessment method   | Requirement  | Result  |
|--|---|--|---|
| Thin-R polyisocyanurate (PIR) board                    | Dimensional stability to BS EN 1604 : 2013 (70°C and 90-100% RH for 48 hours) | Value achieved   | Length and width ≤ 1% change<br>Thickness ≤ 4% change   |
| Thin-R polyisocyanurate (PIR) board                    | Dimensional stability to BS EN 1604 : 1996 (-20°C for 48 hours)               | Value achieved   | Length and width ≤ 0.5% change<br>Thickness ≤ 2% change |
| Thin-R polyisocyanurate (PIR) board at 50 mm thickness | Compressive creep to BS EN 1606 : 1996 (140 kPa at 23°C and 50% RH)           | Extrapolated long term deformation after 10 years value achieved | ≤ 8% deformation  |

### 8.3 Service life

Under normal service conditions, the products will have a life equivalent to the building in which they are incorporated, provided they are designed, installed and maintained in accordance with this Certificate and the Certificate holder's instructions.

## PROCESS ASSESSMENT

Information provided by the Certificate holder was assessed for the following factors:

## 9 Design, installation, workmanship and maintenance

9.1.1 The design process was assessed by the BBA, and the following requirements apply in order to satisfy the performance assessed in this Certificate.

9.1.2 The products can be used on suitably designed beam-and-block floors incorporating Type R2 semi-resisting or resisting blocks to BS EN 15037-2 : 2009 and self-bearing beams to BS EN 15037-1 : 2008.

9.1.3 Ground-bearing floors must only be used where the depth of compacted fill is less than 600 mm and is defined as non-shrinkable. Shrinkable fills are defined as material containing more than 35% fine particles (silt and clay) with a plasticity index of 10% or greater (shrinkable fills are susceptible to clay heave).

9.1.4 Ground-bearing concrete and suspended concrete ground-floors incorporating the products must include a suitable DPM, laid beneath the insulation, in accordance with the relevant sections of CP 102 : 1973, BS 8102 : 2022 and BS 8215 : 1991 (see section A.5 of this Certificate).



9.1.5 Suspended concrete or timber ground-floors incorporating the products must include suitable ventilation of the sub-floor void (minimum 150 mm void between the underside of the floor and the ground surface) or a DPM. For suspended floors in locations where clay heave is anticipated, an additional void of up to 150 mm may be required to accommodate the possible expansion of the ground below the floor. In such cases where the risk of clay heave has been confirmed by geotechnical investigations by a suitably competent and experienced individual, a total void of up to 300 mm may be required.

9.1.6 Where a concrete screed or slab finish is to be laid directly over the products, a polyethylene separating layer/AVCL must be installed between the insulation and the concrete to prevent chemical attack and seepage between the boards (see section A.6). Any gaps between insulation boards or around service openings, visible prior to installing the concrete, must be filled with expanding foam or strips of insulation.

9.1.7 Internal walls must not be built on the insulation.

9.1.8 Care must be taken in the overall design and construction of junctions with other elements and openings to minimise thermal bridges and air infiltration and the detailed guidance that can be found in the documents supporting the national Building Regulations must be followed.

#### *Interstitial condensation*

9.1.9 Floors will adequately limit the risk of interstitial condensation when they are designed and constructed in accordance with BS 5250 : 2021.

9.1.10 When the products are used above the DPM on a ground-bearing or suspended floor, an AVCL is installed on the warm side of the insulation to limit the risk of interstitial condensation, unless a risk assessment shows this is not necessary.

9.1.11 For suspended timber ground floors, it is not necessary to introduce an AVCL as long as adequate sub-floor cross ventilation is provided.

#### *Surface condensation*

9.1.12 In England and Wales, floors will adequately limit the risk of surface condensation when the thermal transmittance (U value) does not exceed  $0.7 \text{ W}\cdot\text{m}^{-2}\cdot\text{K}^{-1}$  at any point, and the junctions with walls are designed in accordance with section 6 of this Certificate.

9.1.13 Floors will adequately limit the risk of surface condensation when the thermal transmittance (U value) does not exceed  $1.2 \text{ W}\cdot\text{m}^{-2}\cdot\text{K}^{-1}$  at any point and the floor is designed and constructed in accordance with the relevant parts of BS 5250 : 2021.

9.1.14 Further guidance may be obtained from BRE Report BR 262 : 2002 and section 6 of this Certificate.

## 9.2 Installation

9.2.1 Installation instructions provided by the Certificate holder were assessed and judged to be appropriate and adequate.

9.2.2 Installation must be carried out in accordance with this Certificate and the Certificate holder's instructions. A summary of instructions and guidance are provided in Annex A of this Certificate.

#### *Incorporation of services*

9.2.3 De-rating of electrical cables must be considered where the insulation restricts air cooling of cables; the products must not be used in direct contact with electrical heating cables or hot water pipes. Where underfloor heating systems are to be used, the advice of the Certificate holder should be sought, but such advice is outside of the scope of this Certificate.

9.2.4 Where possible, electrical conduits, gas and water pipes or other services must be contained within ducts or channels within the concrete slab of ground bearing floors. Where this is not possible, the services may be accommodated within the insulation, provided they are securely fixed to the concrete slab. Electrical cables that are likely to come into contact with the insulation must be protected by a suitable conduit or PVC-U trunking. With hot pipes, the insulation must be cut back to maintain an air space.

9.2.5 Where water pipes are installed below the insulation, they must be pre-lagged with close-fitting pipe insulation.

9.2.6 Where the products are installed on a floor of a suspended beam-and-block design, all services must be installed in accordance with a BBA Certificate for that floor and/or with the relevant codes of practice.

9.2.7 To provide support for a particle board cover on overlay board floors where access to the services is desirable, a duct may be formed by mechanically fixing to the floor, timber bearers of the same thickness as the insulation. The duct must be as narrow as possible and not exceed 400 mm in width or the maximum particle board spans given in PD CEN/TR 12872 : 2014 without intermediate support. Services must be suitably fixed to the floor base and not to the insulation boards (see section 9.1.8 of this Certificate regarding limiting heat loss).

9.2.8 On suspended timber ground floors, all the services must be incorporated beneath the existing floor, if possible.

9.2.9 The products may be installed between timber floor joists using timber stop beads. Tongue-and-groove particle board flooring or softwood floor boarding is then installed in the conventional manner.

### 9.3 Workmanship

Practicability of installation was assessed by the BBA on the basis of the Certificate holder's information. To achieve the performance described in this Certificate, installation of the products must be carried out by a competent general builder, or a contractor, experienced with these types of products.

### 9.4 Maintenance and repair

As the products are confined within the floor by the overlay and have suitable durability, maintenance is not required.

## **10 Manufacture**

10.1 The production processes for the products have been assessed, and provide assurance that the quality controls are satisfactory according to the following factors:

10.1.1 The manufacturer has provided documented information on the materials, processes, testing and control factors.

10.1.2 The quality control operated over batches of incoming materials has been assessed and deemed appropriate and adequate.

10.1.3 The quality control procedures and product testing to be undertaken have been assessed and deemed appropriate and adequate.

10.1.4 The process for management of non-conformities has been assessed and deemed appropriate and adequate.

10.1.5 An audit of each production location was undertaken, and it was confirmed that the production process was in accordance with the documented process, and that equipment has been properly tested and calibrated.

† 10.2 The BBA has undertaken to review the above measures on a regular basis through a surveillance process, to verify that the specifications and quality control operated by the manufacturer are being maintained.

## **11 Delivery and site handling**

11.1 The Certificate holder stated that the products are delivered to site in in polythene-wrapped packs. Each pack contains a label with the manufacturer's name, board dimensions and the BBA logo incorporating the number of this Certificate.

11.2 Delivery and site handing must be performed in accordance with the Certificate holder's instructions and this Certificate, including:

11.2.1 The products must be protected from prolonged exposure to sunlight, and should be stored dry, flat and raised above ground level (to avoid contact with ground moisture). Where possible, packs should be stored inside. If stored outside, they should be under cover, or protected with opaque polythene sheeting.

11.2.2 The products are light and easy to handle; care should be taken to avoid crushing the edges or corners. If damaged, the products should be discarded.

11.2.3 The products must not be exposed to open flame or other ignition sources, or to solvents or other chemicals.

Supporting information in this Annex is relevant to the products but has not formed part of the material assessed for the Certificate.

**Construction (Design and Management) Regulations 2015**

**Construction (Design and Management) Regulations (Northern Ireland) 2016**

Information in this Certificate may assist the client, designer (including Principal Designer) and contractor (including Principal Contractor) to address their obligations under these Regulations.

**CE marking**

The Certificate holder has taken the responsibility of CE marking the products in accordance with harmonised European Standard EN 13165 : 2012.

**Management Systems Certification for production**

The management system of the manufacturer has been assessed and registered as meeting the requirements of BS EN ISO 9001 : 2015, BS EN ISO 14001 : 2015 and BS ISO 45001 : 2018, by BRE (Certificates 718 QMS, 718 EMS and 718 HS respectively).

**Additional information on installation**

A.1 Typical methods of installation are shown in Figures 1 to 8. Reference should also be made to BRE Report BR 262 : 2002.

*Figure 1 Ground-supported concrete floor – screed overlay*

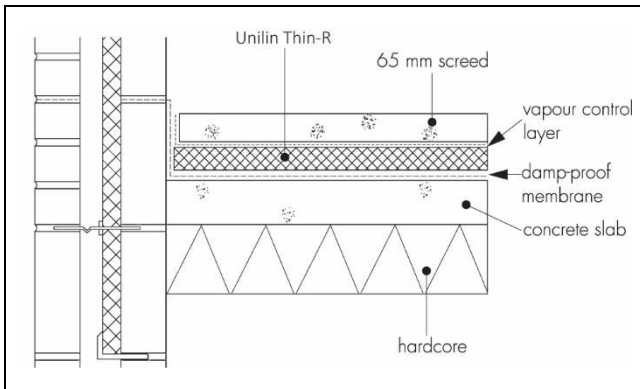

*Figure 2 Suspended concrete floor – screed overlay*

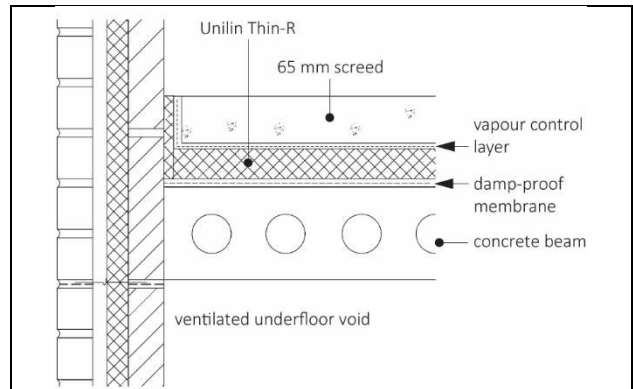

*Figure 3 Concrete slab overlay*

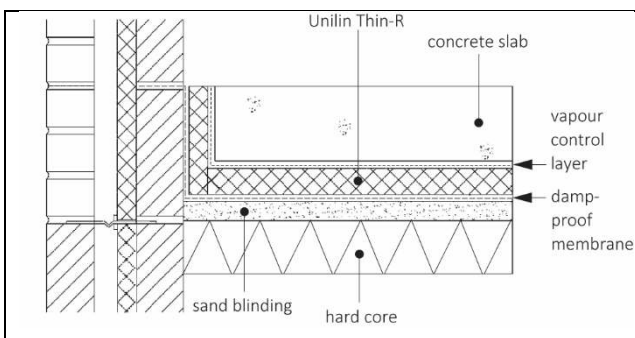

*Figure 4 Ground-supported concrete floor – board overlay*

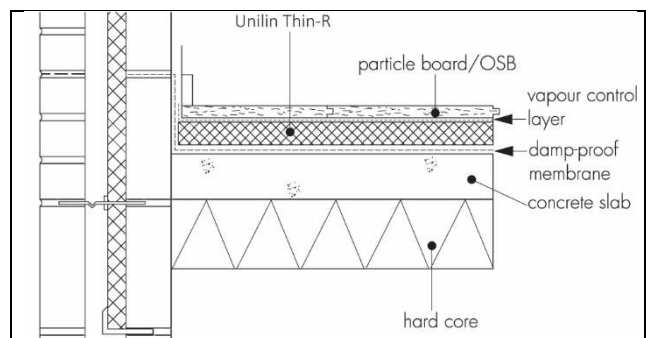

**Figure 5 Suspended concrete floor – board overlay**

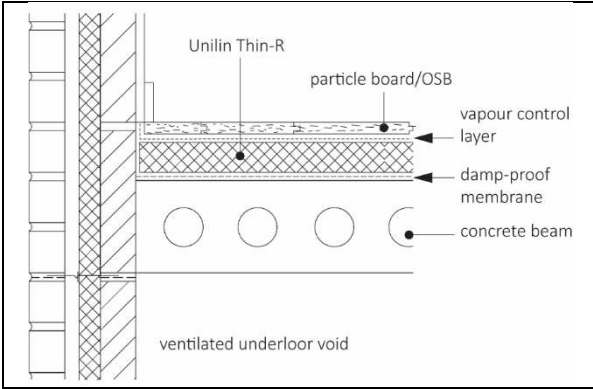

**Figure 6 Ground-supported blinded hardcore – board overlay**

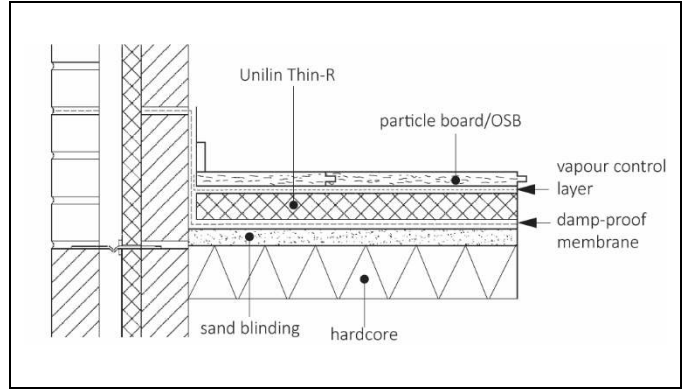

**Figure 7 Suspended timber floors**

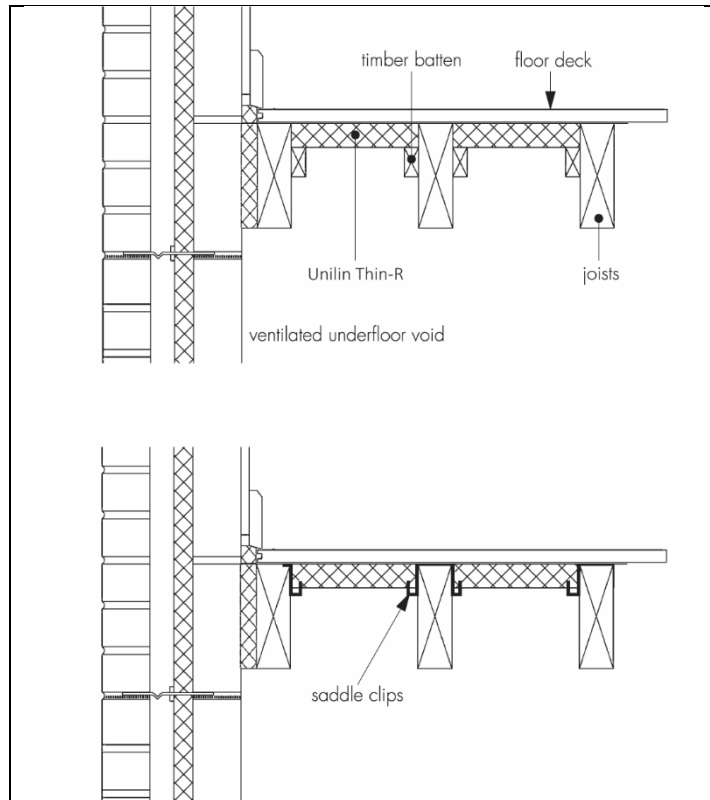

**Figure 8 Beam-and-block floor – screed overlay**

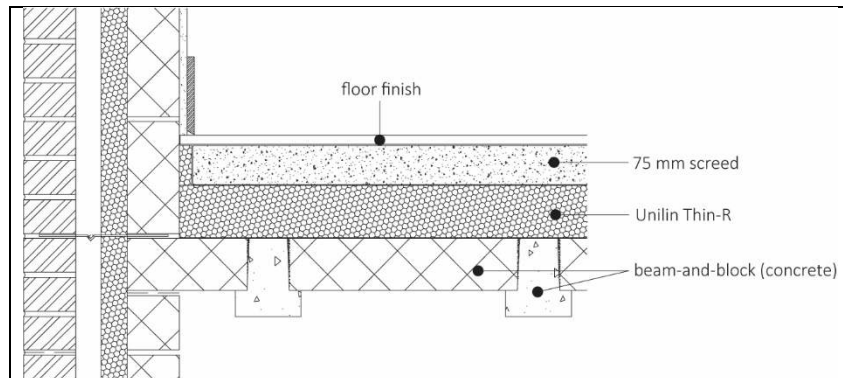

A.2 In ground-bearing concrete floors, the concrete floor slab over which the boards are to be laid should be left for as long as possible to maximise drying out and dissipation of constructional moisture, in accordance with BS 8203 : 2017, Section 3.1.2.

A.3 The concrete floor surface should be smooth, level, and flat to within 5 mm when measured with a two-metre straight-edge. Irregularities greater than this must be removed. Minor irregularities (up to 10 mm deep) may be levelled with mortar or thin screed.

A.4 Where the insulation is used over ground-bearing concrete floor slabs, a suitable DPM in accordance with CP 102 : 1973 should be laid to resist moisture from the ground. If a liquid-type DPM is applied to the slabs, it should be of a type compatible with the products and be allowed to dry out fully before laying the insulation.

A.5 Where the insulation is used on hardcore bases beneath ground-bearing concrete slabs, the hardcore must be compacted and blinded with a thin layer of sand before application of the DPM, followed by the insulation boards.

A.6 An AVCL is installed on the warm side of the insulation to inhibit the risk of interstitial condensation if necessary (see section 3 of this Certificate). Where a concrete screed or slab finish is to be laid directly over the products, a polyethylene separating layer/AVCL must be installed between the insulation and the concrete to prevent chemical attack and seepage between the boards.

A.7 Where a screed or concrete slab is laid over the insulation, vertical upstands of insulation should be provided and be of sufficient depth to fully separate the screed or slab from the wall. If used, a suitable cavity wall insulation material should be extended below the damp-proof course (DPC) level to provide edge insulation to the floor.

A.8 To limit the risk of condensation and other sources of dampness, the insulation and overlays should only be laid after the construction is made substantially weathertight, eg, after glazing. During construction, the insulation and overlay must be protected from damage by traffic and moisture sources such as water spillage and plaster droppings.

#### Procedure

A.9 The products are cut to size (using a sharp knife or fine-toothed saw), as necessary, and laid with closely butted, staggered cross-joints, ensuring all spaces are completely filled.

A.10 The laying pattern should ensure that all cut edges are at the perimeter of the floor or some other feature, eg, mat wells, thresholds or access ducts. Spreader boards should be used to protect the insulation.

#### **Timber-based board overlay**

A.11 Before laying the plywood, particle board or OSB overlay, preservative-treated timber battens, in accordance with BS 8417 : 2011, are positioned at doorways and access panels. Adequate time should be allowed for preservatives to be fixed, and the solvents from solvent-based preservatives to evaporate.

A.12 Where the insulation is laid above a DPM, a polyethylene AVCL of at least 0.125 mm (500 gauge) thickness is laid between the insulation and the timber board overlay. The AVCL should have 150 mm overlaps, taped at the joints and turned up 100 mm at the walls.

A.13 Timber based overlay boards as specified in section 9 of this Certificate are laid with staggered cross-joints, in accordance with PD CEN/TR 12872 : 2014 and BS EN 12871 : 2013.

A.14 An expansion gap between the overlay board and the perimeter walls should be provided at the rate of 2 mm per metre run or a minimum of 10 mm, whichever is the greater.

A.15 Where there are long, uninterrupted lengths of floor (eg, corridors), proprietary expansion joints should be installed at intervals, on the basis of a 2 mm gap per metre run of overlay board.

A.16 Before the overlay boards are interlocked, a waterproof PVA adhesive is applied to the joints.

A.17 Once the overlay board is laid, temporary wedges are inserted between the walls and the floor to maintain tight joints until the adhesive has set.

A.18 When the wedges are removed and before the skirting boards are fixed, a suitable compressible filler, eg, foamed polyethylene, should be fitted around the perimeter of the floor between the overlay board and the walls.

A.19 Where there is a likelihood of regular water spillage (eg, in kitchens, bathrooms, shower and utility rooms), additional overlay board protection should be considered, eg, by a continuous flexible vinyl sheet flooring, with welded joints, turned up at abutments and cove skirting.

#### **Cement-based screed overlay**

A.20 Perimeter edge pieces are cut and placed around the edges and taped at joints. A polyethylene AVCL, at least 0.125 mm thick (500 gauge), is laid over the insulation. The AVCL should have 150 mm overlaps, taped at the joints and turned up 100 mm at the walls. A properly compacted screed of minimum thickness 65 mm is then laid over. The relevant clauses of BS 8204-1 : 2003 should be followed.

#### **Concrete slab overlay (ground-bearing only)**

A.21 Perimeter edge pieces are cut and placed around the edges and taped at the joints. A polyethylene AVCL, minimum 0.125 mm thick (500 gauge), is laid over the insulation. The AVCL should have 150 mm overlaps, taped at the joints and turned up 100 mm at the walls. The concrete slab is laid to the required thickness in accordance with BS 8000-9 : 2003 and BS 8204-1 : 2003.

#### **Suspended timber floors**

A.22 Insulation boards can be supported between timber joists using either saddle clips or timber beads. Where timber beads are used, a void may be incorporated above the insulation to accommodate services, if required.

A.23 Saddle clips are placed at intervals not exceeding one metre along the timber floor joists. Where the products are to be installed on only one side of the joist, twin clips can be cut into single clips and nailed into place with galvanized nails.

A.24 If saddle clips are not used, the products may be retained using preservative-treated timber battens. The battens should be wide enough to retain the products in place and secured with corrosion-protected nails at a depth that will accommodate the thickness of the products.

A.25 The products should be cut to fit tightly between joists and pushed down onto the spikes of the saddle clips, or onto the beads. Small gaps should be insulated with cut strips of the products.

#### **Beam and block floors**

A.26 All surfaces must be level prior to installation

A.27 The floor surface must be smooth; any uneven surfaces should be levelled prior to laying of the floor and any irregularities should be removed by a levelling screed.

A.28 A DPM is laid, ensuring it is correctly positioned and turned up to meet the seal with the DPC.

A.29 If required, the boards are overlaid with 500-gauge polythene sheet to prevent the wet screed from penetrating the joints between the insulation boards.

## Bibliography

- BRE Report BR 262 : 2002 *Thermal insulation: avoiding risks*
- BRE Report BR 443 : 2019 *Conventions for U-value calculations*
- BS 3177 : 1959 *Method for determining the permeability to water vapour of flexible sheet materials used for packaging*
- BS 5250 : 2021 *Management of moisture in buildings. Code of practice*
- BS 8000-9 : 2003 *Workmanship on building sites — Cementitious levelling screeds and wearing screeds — Code of practice*
- BS 8102 : 2022 *Protection of below ground structures against water ingress — Code of practice*
- BS 8203 : 2017 *Code of practice for installation of resilient floor coverings*
- BS 8204-1 : 2003 + A1 : 2009 *Screeds, bases and in-situ floorings — Concrete bases and cement sand levelling screeds to receive floorings — Code of practice*
- BS 8204-2 : 2003 + A2 : 2011 *Screeds, bases and in-situ floorings — Concrete wearing surfaces — Code of practice*
- BS 8215 : 1991 *Code of practice for design and installation of damp-proof courses in masonry construction*
- BS 8417 : 2011 + A1 : 2014 *Preservation of wood — Code of practice*
- BS EN 300 : 2006 *Oriented Strand Boards (OSB) — Definitions, classification and specifications*
- BS EN 312 : 2010 *Particleboards — Specifications*
- BS EN 636 : 2012 + A1 : 2015 *Plywood — Specifications*
- BS EN 826 : 2013 *Thermal insulating products for building applications — Determination of compression behaviour*
- BS EN 1604 : 1997 *Thermal insulating products for building applications — Determination of dimensional stability under specified temperature and humidity conditions*
- BS EN 1604 : 1996 *Thermal insulating products for building applications — Determination of dimensional stability under specified temperature and humidity conditions*
- BS EN 1604 : 2013 *Thermal insulating products for building applications — Determination of dimensional stability under specified temperature and humidity conditions*
- BS EN 1606 : 1996 *Thermal insulating products for building applications — Determination of compressive creep*
- NA to BS EN 1991-1-1 : 2002 *UK National Annex to Eurocode 1 : Actions on structures — General actions — Densities, self-weight, imposed loads for buildings*
- BS EN 1992-1-1 : 2004 + A1 : 2014 *Eurocode 2 : Design of concrete structures — General rules and rules for buildings*
- BS EN 12871 : 2013 *Wood-based panels — Performance specifications and requirements for load bearing boards for use in floors, walls and roofs*
- BS EN 13165 : 2012 + A2 : 2016 *Thermal insulation products for buildings — Factory made rigid polyurethane foam (PUR) products — Specification*
- BS EN 13501-1 : 2018 *Fire classification of construction products and building elements — Classification using test data from reaction to fire tests*
- BS EN 13810-1 : 2002 *Wood-based panels — Floating floors — Performance specifications and requirements*
- BS EN 15037-1 : 2008 *Precast concrete products — Beam-and-block floor systems — Beams*
- BS EN 15037-2 : 2009 + A1 : 2011 *Precast concrete products — Beam-and-block floor systems — Concrete blocks*
- BS EN ISO 9001 : 2015 *Quality management systems — Requirements*
- BS EN ISO 10456 : 2007 : *Building materials and products. Hygrothermal properties. Tabulated design values and procedures for determining declared and design thermal values*
- BS EN ISO 14001 : 2015 *Environmental Management systems — Requirements with guidance for use*



BS ISO 45001 : 2018 *Occupational health and safety management systems — Requirements with guidance for use*

CP 102 : 1973 *Code of practice for protection of buildings against water from the ground*

DD CEN/TS 13810-2 : 2003 *Wood-based panels — Floating floors — Test methods*

PD CEN/TR 12872 : 2014 *Wood-based panels — Guidance on the use of load-bearing boards in floors, walls and roofs*

## Conditions of Certificate

### Conditions

1 This Certificate:

- relates only to the product that is named and described on the front page
- is issued only to the company, firm, organisation or person named on the front page – no other company, firm, organisation or person may hold or claim that this Certificate has been issued to them
- is valid only within the UK
- has to be read, considered and used as a whole document – it may be misleading and will be incomplete to be selective
- is copyright of the BBA
- is subject to English Law.

2 Publications, documents, specifications, legislation, regulations, standards and the like referenced in this Certificate are those that were current and/or deemed relevant by the BBA at the date of issue or reissue of this Certificate.

3 This Certificate will be displayed on the BBA website, and the Certificate Holder is entitled to use the Certificate and Certificate logo, provided that the product and its manufacture and/or fabrication, including all related and relevant parts and processes thereof:

- are maintained at or above the levels which have been assessed and found to be satisfactory by the BBA
- continue to be checked as and when deemed appropriate by the BBA under arrangements that it will determine
- are reviewed by the BBA as and when it considers appropriate.

4 The BBA has used due skill, care and diligence in preparing this Certificate, but no warranty is provided.

5 In issuing this Certificate the BBA is not responsible and is excluded from any liability to any company, firm, organisation or person, for any matters arising directly or indirectly from:

- the presence or absence of any patent, intellectual property or similar rights subsisting in the product or any other product
- the right of the Certificate holder to manufacture, supply, install, maintain or market the product
- actual installations of the product, including their nature, design, methods, performance, workmanship and maintenance
- any works and constructions in which the product is installed, including their nature, design, methods, performance, workmanship and maintenance
- any loss or damage, including personal injury, howsoever caused by the product, including its manufacture, supply, installation, use, maintenance and removal
- any claims by the manufacturer relating to UKCA marking and CE marking.

6 Any information relating to the manufacture, supply, installation, use, maintenance and removal of this product which is contained or referred to in this Certificate is the minimum required to be met when the product is manufactured, supplied, installed, used, maintained and removed. It does not purport in any way to restate the requirements of the Health and Safety at Work etc. Act 1974, or of any other statutory, common law or other duty which may exist at the date of issue or reissue of this Certificate; nor is conformity with such information to be taken as satisfying the requirements of the 1974 Act or of any statutory, common law or other duty of care.

### British Board of Agrément

1<sup>st</sup> Floor, Building 3, Hatters Lane  
Croxley Park, Watford  
Herts WD18 8YG

©2023

tel: 01923 665300  
clientservices@bbacerts.co.uk  
[www.bbacerts.co.uk](http://www.bbacerts.co.uk)