

Xtratherm UK Ltd

Park Road
Holmewood Industrial Park
Holmewood
Chesterfield
Derbyshire S42 5UY

Tel: 0371 222 1033 Fax: 0371 222 1044

e-mail: info@xtratherm.com

website: www.xtratherm.com



Agrément Certificate

10/4803

Product Sheet 2

XTRATHERM SAFE-R INSULATION

XTRATHERM SAFE-R PARTIAL FILL CAVITY (SR/CW) BOARD

This Agrément Certificate Product Sheet⁽¹⁾ relates to Xtratherm Safe-R Partial Fill Cavity (SR/CW) Board, comprising rigid phenolic (PF) foam board with a composite foil-facing on both sides, for use as partial fill insulation to reduce the thermal transmittance of cavity walls in new buildings of a domestic or non-domestic nature with masonry inner and outer leaves.

(1) Hereinafter referred to as 'Certificate'.

CERTIFICATION INCLUDES:

- factors relating to compliance with Building Regulations where applicable
- factors relating to additional non-regulatory information where applicable
- independently verified technical specification
- assessment criteria and technical investigations
- design considerations
- installation guidance
- regular surveillance of production
- formal three-yearly review.

KEY FACTORS ASSESSED

Thermal performance — the product has declared thermal conductivities (λ_D) of $0.020 \text{ W}\cdot\text{m}^{-1}\cdot\text{K}^{-1}$ or $0.021 \text{ W}\cdot\text{m}^{-1}\cdot\text{K}^{-1}$, depending on thickness (see section 6).

Condensation risk — the product can contribute to limiting the risk of condensation (see section 8).

Properties in relation to fire — the Certificate holder has not declared a reaction to fire classification to BS EN 13501-1 : 2018 and the use of the product is restricted in some cases (see section 9).

Durability — the product is durable, rot proof, water resistant and sufficiently stable to remain effective as insulation for the life of the building (see section 12).



The BBA has awarded this Certificate to the company named above for the product described herein. This product has been assessed by the BBA as being fit for its intended use provided it is installed, used and maintained as set out in this Certificate.

On behalf of the British Board of Agrément

Date of Third issue: 9 May 2017

John Albon – Head of Approvals
Construction Products

Originally certificated on 14 December 2010

Certificate amended on 20 May 2019 to include Regulation 7(2) for England and associated text.

Certificate amended on 18 June 2020 to include new regulatory guidance for fire in Scotland and Wales.

Claire Curtis-Thomas
Chief Executive

The BBA is a UKAS accredited certification body – Number 113.

The schedule of the current scope of accreditation for product certification is available in pdf format via the UKAS link on the BBA website at www.bbacerts.co.uk

Readers MUST check the validity and latest issue number of this Agrément Certificate by either referring to the BBA website or contacting the BBA directly.

Any photographs are for illustrative purposes only, do not constitute advice and should not be relied upon.

British Board of Agrément

Bucknalls Lane
Watford
Herts WD25 9BA

©2017

tel: 01923 665300
clientservices@bbacerts.co.uk
www.bbacerts.co.uk

Regulations

In the opinion of the BBA, Xtratherm Safe-R Partial Fill Cavity (SR/CW) Board, if installed, used and maintained in accordance with this Certificate, can satisfy or contribute to satisfying the relevant requirements of the following Building Regulations (the presence of a UK map indicates that the subject is related to the Building Regulations in the region or regions of the UK depicted):



The Building Regulations 2010 (England and Wales) (as amended)

Requirement:	B3(4)	Internal fire spread (structure)
Comment:		The product is restricted by this Requirement. See section 9.1 of this Certificate.
Requirement:	B4(1)	External fire spread
Comment:		The product is restricted by this Requirement in some cases. See sections 9.1 and 9.3 of this Certificate.
Requirement:	C2(a)	Resistance to moisture
Comment:		The product can contribute to satisfying this Requirement. See section 7.1 of this Certificate.
Requirement:	C2(b)	Resistance to moisture
Comment:		The product can contribute to satisfying this Requirement. See section 7.2 of this Certificate.
Requirement:	C2(c)	Resistance to moisture
Comment:		The product can contribute to satisfying this Requirement. See sections 8.1 and 8.5 of this Certificate.
Requirement:	L1(a)(i)	Conservation of fuel and power
Comment:		The product can contribute to satisfying this Requirement. See section 6 of this Certificate.
Regulation:	7(1)	Materials and workmanship
Comment:		The product is acceptable. See section 12 and <i>Installation</i> part of this Certificate.
Regulation:	7(2)	Materials and workmanship
Comment:		The product is restricted by this Regulation. See sections 9.1 and 9.2 of this Certificate.
Regulation:	26	CO₂ emission rates for new buildings
Regulation:	26A	Fabric energy efficiency rates for new dwellings (applicable to England only)
Regulation:	26A	Primary energy consumption rates for new buildings (applicable in Wales only)
Regulation:	26B	Fabric performance values for new dwellings (applicable to Wales only)
Comment:		The product can contribute to satisfying these Regulations. See section 6 of this Certificate.



The Building (Scotland) Regulations 2004 (as amended)

Regulation:	8(1)	Durability, workmanship and fitness of materials
Comment:		The product is acceptable. See section 12 and the <i>Installation</i> part of this Certificate.
Regulation:	9	Building standards applicable to construction
Standard:	2.4	Cavities
Comment:		The product is restricted by this Standard, with reference to clause 2.4.2 ⁽¹⁾⁽²⁾ . See section 9.1 of this Certificate.
Standard:	2.6	Spread to neighbouring buildings
Comment:		The product is restricted by this Standard in some cases, with reference to clauses 2.6.5 ⁽¹⁾ and 2.6.6 ⁽²⁾ . See sections 9.1 and 9.4 of this Certificate.

Standard:	2.7	Spread external walls
Comment:		The product is restricted by this Standard with respect to clause 2.7.2 ⁽²⁾ . See sections 9.1, 9.4 and 9.5 of this Certificate.
Standard:	3.4	Moisture from the ground
Comment:		The product can contribute to satisfying this Standard, with reference to clauses 3.4.1 ⁽¹⁾⁽²⁾ and 3.4.5 ⁽¹⁾⁽²⁾ of this Standard. See section 7.1 of this Certificate.
Standard:	3.10	Precipitation
Comment:		The product can contribute to satisfying this Standard, with reference to clauses 3.10.1 ⁽¹⁾⁽²⁾ and 3.10.3 ⁽¹⁾⁽²⁾ . See section 7.2 of this Certificate.
Standard:	3.15	Condensation
Comment:		The product can contribute to satisfying this Standard, with reference to clauses 3.15.1 ⁽¹⁾⁽²⁾ , 3.15.4 ⁽¹⁾⁽²⁾ and 3.15.5 ⁽¹⁾⁽²⁾ . See sections 8.1 and 8.6 of this Certificate.
Standard:	6.1(b)	Carbon dioxide emissions
Standard:	6.2	Building insulation envelope
Comment:		The product can contribute to satisfying these Standards, with reference to clauses, or parts of, 6.1.1 ⁽¹⁾ , 6.1.2 ⁽²⁾ , 6.1.6 ⁽¹⁾ , 6.2.1 ⁽¹⁾⁽²⁾ , 6.2.3 ⁽¹⁾ , 6.2.4 ⁽²⁾ , 6.2.5 ⁽²⁾ , 6.2.9 ⁽¹⁾ , 6.2.10 ⁽¹⁾ , 6.2.11 ⁽¹⁾⁽²⁾ and 6.2.13 ⁽²⁾ . See section 6 of this Certificate.
Standard:	7.1(a)(b)	Statement of sustainability
Comment:		The product can contribute to meeting the relevant requirements of Regulation 9, Standards 1 to 6, and therefore will contribute to a construction meeting a bronze level of sustainability as defined in this Standard. In addition, the product can contribute to a construction meeting a higher level of sustainability as defined in this Standard, with reference to clauses 7.1.4 ⁽¹⁾⁽²⁾ [Aspects 1 ⁽¹⁾⁽²⁾ and 2 ⁽¹⁾], 7.1.6 ⁽¹⁾⁽²⁾ [Aspects 1 ⁽¹⁾⁽²⁾ and 2 ⁽¹⁾] and 7.1.7 ⁽¹⁾⁽²⁾ [Aspect 1 ⁽¹⁾⁽²⁾]. See section 6 of this Certificate.
Regulation:	12	Building standards applicable to conversions
Comment:		All comments given for the product under Regulation 9, Standards 1 to 6, also apply to this Regulation, with reference to clause 0.12.1 ⁽¹⁾⁽²⁾ and Schedule 6 ⁽¹⁾⁽²⁾ .
Standard:	7.1(a)	Statement of sustainability
Comment:		The product can contribute to meeting the relevant requirements of Regulation 9, Standards 1 to 6, and therefore will contribute to a construction meeting a bronze level of sustainability as defined in this Standard.

(1) Technical Handbook (Domestic).
(2) Technical Handbook (Non-Domestic).



The Building Regulations (Northern Ireland) 2012 (as amended)

Regulation:	23	Fitness of materials and workmanship
Comment:		The product is acceptable. See section 12 and the <i>Installation</i> part of this Certificate.
Regulation:	28(a)	Resistance to moisture and weather
Comment:		The product can contribute to satisfying this Regulation. See section 7.1 of this Certificate.
Regulation:	28(b)	Resistance to moisture and weather
Comment:		The product can contribute to satisfying this Regulation. See section 7.2 of this Certificate.
Regulation:	29	Condensation
Comment:		The product can contribute to satisfying this Regulation. See section 8.1 of this Certificate.

Regulation: 35(4)	Internal fire spread – structure
Comment:	The product is restricted by this Regulation. See section 9.1 of this Certificate.
Requirement: 36(a)	External fire spread
Comment:	The product is restricted by this Regulation in some cases. See sections 9.1 and 9.3 of this Certificate.
Regulation: 39(a)(i)	Conservation measures
Regulation: 40(2)	Target carbon dioxide emission rate
Comment:	The product can contribute to satisfying these Regulations. See section 6 of this Certificate.

Construction (Design and Management) Regulations 2015 Construction (Design and Management) Regulations (Northern Ireland) 2016

Information in this Certificate may assist the client, designer (including Principal Designer) and contractor (including Principal Contractor) to address their obligations under these Regulations.

See section: 3 *Delivery and site handling* (3.4) of this Certificate.

Additional Information

NHBC Standards 2017

Subject to a 50 mm minimum residual cavity being maintained, NHBC accepts the use of Xtratherm Safe-R Partial Fill Cavity (SR/CW) Board, provided it is installed, used and maintained in accordance with this Certificate, in relation to *NHBC Standards*, Chapter 6.1 *External masonry walls*.

CE marking

The Certificate holder has taken the responsibility of CE marking the product, in accordance with harmonised European Standard BS EN 13166 : 2012. An asterisk (*) appearing in this Certificate indicates that data shown are given in the manufacturer's Declaration of Performance.

Technical Specification

1 Description

1.1 Xtratherm Safe-R Partial Fill Cavity (SR/CW) Board comprises closed-cell rigid phenolic (PF) foam, faced with a composite foil-facing on both sides.

1.2 The product has the nominal characteristics shown in Table 1.

Table 1 Nominal characteristics

Length (mm)	1200
Width (mm)	450
Thickness (mm)	50, 60, 70, 75, 80, 100, 120
Minimum compressive strength* at 10% compression (kPa)	120
Edge profile	Square

2 Manufacture

2.1 Raw materials are injected onto the lower foil-facer on a conveyor belt. The exothermic reaction expands the foam, which then comes into contact with the upper foil-facer. An automated process cures and cuts the product to the required size.

2.2 As part of the assessment and ongoing surveillance of product quality, the BBA has:

- agreed with the manufacturer the quality control procedures and product testing to be undertaken
- assessed and agreed the quality control operated over batches of incoming materials
- monitored the production process and verified that it is in accordance with the documented process.
- evaluated the process for management of nonconformities
- checked that equipment has been properly tested and calibrated
- undertaken to carry out the above measures on a regular basis through a surveillance process, to verify that the specifications and quality control operated by the manufacturer are being maintained.

2.3 The management system of Xtratherm UK Ltd has been assessed and registered as meeting the requirements of BS EN ISO 9001 : 2008 and BS EN ISO 14001 : 2004 by BRE Certification Ltd (Certificate 718 and EMS 718 respectively).

3 Delivery and site handling

3.1 The product is delivered to site in polythene-wrapped packs. Each pack contains a label with the manufacturer's name, board dimensions and the BBA logo incorporating the number of this Certificate.

3.2 The product must be protected from prolonged exposure to sunlight, and should be stored dry, flat and raised above ground level (to avoid contact with ground moisture). Where possible, packs should be stored inside. If stored outside, they should be under cover or protected with opaque polythene sheeting.

3.3 The product is light and easy to handle; care should be taken to avoid crushing the edges or corners. If damaged, the product should be discarded.

3.4 The product must not be exposed to open flame or other ignition sources, or to solvents or other chemicals.

Assessment and Technical Investigations

The following is a summary of the assessment and technical investigations carried out on Xtratherm Safe-R Partial Fill Cavity (SR/CW) Board.

Design Considerations

4 Use

4.1 Xtratherm Safe-R Partial Fill Cavity (SR/CW) Board is satisfactory for use as partial fill cavity wall insulation and is effective in reducing the thermal transmittance (U value) of external cavity walls with masonry inner and outer leaves (where masonry includes clay and calcium silicate bricks, concrete blocks, and natural and reconstituted stone blocks). The product is for use in new domestic and non-domestic. It is essential that such walls are designed and constructed to incorporate the precautions in this Certificate to prevent moisture penetration.

4.2 Buildings subject to the national Building Regulations should be constructed in accordance with the relevant recommendations of:

- BS EN 1996-1-1 : 2005, BS EN 1996-1-2 : 2005, BS EN 1996-2 : 2006 and BS EN 1996-3 : 2006 and their respective UK National Annexes
- BS EN 845-1 : 2013 and BS 8000-3 : 2001.

4.3 New buildings not subject to these Regulations should also be built in accordance with the Standards given in section 4.2 of this Certificate.

4.4 As with other forms of cavity wall insulation, where buildings need to comply with *NHBC Standards 2017*, specifiers should observe the requirements of that document.

4.5 Cavity wall ties with insulation-retaining fixings and, if required, any additional ties to BS EN 845-1 : 2013 should be used for structural stability in accordance with BS EN 1996-1-1 : 2005, BS EN 1996-2 : 2006 and BS EN 1996-3 : 2006.

4.6 Care must be taken in the overall design and construction of walls incorporating the product to ensure the provision of appropriate:

- cavity trays and damp-proof courses (dpc's)
- cavity barriers and fire dampers
- resistance to the ingress of precipitation, moisture and dangerous gases from the ground
- resistance to sound transmission when flanking separating walls and floors.

4.7 The use of cavity battens or boards is strongly recommended to prevent thermal bridging by mortar droppings.

Buildings up to and including 25 metres high

4.8 The residual cavity width to be maintained during construction is 50 mm. This may reduce to 25 mm in isolated areas due to individual construction features (a minimum of 50 mm residual cavity width is required by the NHBC). This may be achieved by designing a cavity width which takes into account the dimensional tolerances of the components which make up the wall (by reference to the British Standards relating to the bricks, blocks and slabs), or by using the data from the respective manufacturers. Allowances may need to be made for the quality of building operatives and the degree of site supervision or control available. The limitations in respect of exposure of the proposed building as set out in Table 2 must also be observed.

Table 2 Maximum allowable total exposure factors of different constructions

Construction	Maximum allowable exposure factor (E) ⁽¹⁾
All external masonry walls protected by: rendering (to BS EN 13914-1 : 2016), tile hanging, slate hanging, or timber, plastic or metal weatherboarding or cladding	No restriction
One or more external masonry walls constructed from facing clay brickwork or natural stone, the porosity of which exceeds 20% by volume. Mortar joints must be flush pointed or weatherstruck	100
One or more external masonry walls constructed from calcium silicate bricks, concrete blocks, reconstituted stone, or natural stone, the porosity of which is less than 20% by volume, or any material with raked mortar joints	88

(1) To BS 5618 : 1985.

4.9 From ground level, the maximum height of continuous cavity walls must not exceed 12 m; above 12 m, the maximum height of continuous cavity walls must not exceed 7 m. In both cases, breaks should be in the form of continuous horizontal cavity trays and weepholes discharging to the outside.

4.10 An external render coat or other suitable finish should be applied in locations where such applications would be normal practice; care should be taken to ensure that the residual cavity is not bridged by mortar.

Buildings over 25 m in height

4.11 The width of the residual clear cavity to be achieved must be in excess of 50 mm, and the following requirements apply:

- the specifier must take extra care when detailing to ensure that the introduction of the insulation does not affect the weather resistance of the wall. Above average site supervision is recommended during installation of the product
- where, for structural reasons, the cavity width is reduced, eg by the intrusion of ring beams, a minimum residual cavity width of 25 mm must be maintained and extra care must be taken with fixings and weatherproofing, eg the inclusion of cavity trays with weepholes.

5 Practicability of installation

The product is designed to be installed by a competent general builder, or a contractor experienced with this type of product.

6 Thermal performance



6.1 Calculations of thermal transmittance (U value) should be carried out in accordance with BS EN ISO 6946 : 2007 and BRE Report BR 443 : 2006, using the declared thermal conductivities (λ_D) shown in Table 3 and a foil surface emissivity (ϵ) of 0.2.

Table 3 Thermal conductivity

Insulation thickness (mm)	Thermal conductivity ($W \cdot m^{-1} \cdot K^{-1}$)
50 to 99	0.021
100 to 120	0.020

6.2 The U value of a completed wall will depend on the insulation thickness, number and type of fixings, insulating value of the substrate masonry and its internal finish. Calculated U values for example constructions are given in Table 4.

Table 4 Example U values⁽¹⁾ — partial fill insulation (50 mm residual cavity)

U value requirement ($W \cdot m^{-2} \cdot K^{-1}$)	Insulation thickness (mm)	
	13 mm dense plaster ⁽²⁾ 100 mm dense block ⁽³⁾	Plasterboard on dabs 100 mm ACC block ⁽⁴⁾
0.18	100	100
0.19	100	75
0.25	70	50
0.26	70	50
0.27	60	50
0.28	60	50
0.30	60	50
0.35	50	50

(1) Assumes fixings correction for fully-penetrating stainless steel fixings ($17 W \cdot m^{-1} \cdot K^{-1}$) at 2.5 per m^2 with a cross-sectional area of $12.5 mm^2$, nominal U value and 102 mm thick brick outer leaf.

(2) Plaster thermal conductivity of $0.57 W \cdot m^{-1} \cdot K^{-1}$.

(3) Block and mortar thermal conductivity of $1.13 W \cdot m^{-1} \cdot K^{-1}$ and $0.88 W \cdot m^{-1} \cdot K^{-1}$ respectively.

(4) Block and mortar thermal conductivity of $0.12 W \cdot m^{-1} \cdot K^{-1}$ and $0.88 W \cdot m^{-1} \cdot K^{-1}$ respectively.

Junctions



6.3 Care must be taken in the overall design and construction of junctions with other elements and openings to minimise thermal bridges and air infiltration. Detailed guidance can be found in the documents supporting the national Building Regulations.

7 Water resistance



7.1 The product may be used in situations where it bridges the damp-proof course (dpc) in walls; dampness from the ground will not pass through to the inner leaf provided the wall is detailed in accordance with the requirements and provisions of the national Building Regulations.

7.2 Constructions incorporating the product, and built in accordance with the Standards listed in section 4.2, will resist the transfer of precipitation to the inner leaf and satisfy the national Building Regulations.

7.3 In all situations, it is particularly important to ensure during installation that:

- wall ties are installed correctly and are thoroughly clean
- excess mortar is cleaned from the cavity face of the leading leaf and any debris removed from the cavity
- mortar droppings are cleaned from the exposed edges of installed boards
- insulation boards are properly installed and either butt jointed, or interlocked using the tongue-and-groove or rebated edges
- installation is carried out to the highest level on each wall, or the top edge of the insulation is protected by a cavity tray
- at lintel level, a cavity tray, stop ends and weep holes are provided
- cavity battens and/or boards are used during construction to prevent bridging by mortar droppings
- dpc's at ground level do not project into the cavity as they can form a trap for mortar bridging
- raked or recessed mortar joints are avoided in very severe exposure areas.

7.4 Window and door opening reveals should be constructed incorporating a cavity barrier/closer/dpc, as required (see sections 13 and 14).

8 Condensation risk

Interstitial condensation



8.1 Walls will adequately limit the risk of interstitial condensation when they are designed and constructed in accordance with BS 5250 : 2011, Annexes D and G, and the relevant guidance.

8.2 For the purposes of assessing the risk of interstitial condensation, the vapour resistivity/resistance values of the individual components may be taken as:

- phenolic insulation — $171 \text{ MN}\cdot\text{s}\cdot\text{g}^{-1}\cdot\text{m}^{-1}$
- foil facing (each layer) — $0.71 \text{ MN}\cdot\text{s}\cdot\text{g}^{-1}$.

8.3 Joints between boards will facilitate the passage of water vapour under normal conditions of temperature and humidity.

8.4 If the product is to be used in the external walls of rooms expected to have high humidity, care must be taken to provide adequate permanent ventilation to avoid possible problems from the formation of interstitial condensation.

Surface condensation



8.5 Walls will adequately limit the risk of surface condensation when the thermal transmittance (U value) does not exceed $0.7 \text{ W}\cdot\text{m}^{-2}\cdot\text{K}^{-1}$ at any point, and the junctions with other elements are designed in accordance with the guidance referred to in section 6.3 of this Certificate.



8.6 For buildings in Scotland, wall constructions will be acceptable when the thermal transmittance (U value) does not exceed $1.2 \text{ W}\cdot\text{m}^{-2}\cdot\text{K}^{-1}$ at any point, and the junctions with other elements are designed in accordance with the guidance referred to in BS 5250 : 2011, Annex G. Further guidance may be obtained from BRE Report BR 262 : 2002 and section 6.3 of this Certificate.

9 Properties in relation to fire



9.1 The Certificate holder has not declared a reaction to fire classification to BS EN 13501-1 : 2018. The product is not classified as non-combustible or of a limited combustibility.



9.2 In England and Wales, the product should not be used on buildings with a storey 18 m or more above ground level that contains: one or more dwellings, an institution, a room for residential purposes (excluding any room in a hostel, hotel or boarding house), student accommodation, care homes, sheltered housing, hospitals or dormitories in boarding schools.



9.3 In England, Wales and Northern Ireland, the product is unrestricted in terms of proximity to a boundary and, for constructions comprising two leaves of brick or concrete each at least 75 mm thick and with cavities closed around openings and at the top of the wall, is unrestricted in terms of height, other than those described in section 9.2. For other constructions, the product should not be used in buildings with a floor more than 18 m above the ground.



9.4 In Scotland, the product may be used without restriction on height or proximity to a relevant boundary, provided it is installed in a cavity that is between two leaves of masonry at least 75 mm thick, and which has a cavity barrier around all openings in the wall and at the top of the wall head. For other constructions, the product should not be used 1 m or less from a boundary or in a building with a floor more than 18 m above the ground.

9.5 Designers should refer to the relevant national Building Regulations and guidance for detailed conditions of use, particularly in respect of requirements for substrate fire performance, cavity closers and barriers, fire stopping of service penetrations and combustibility limitations for other materials and components used in the overall wall construction.

10 Proximity of flues and appliances

When installing the product in close proximity to certain flue pipes and/or heat-producing appliances, the relevant provisions of the national Building Regulations are applicable:

England and Wales — Approved Document J, sections 1 to 4

Scotland — Mandatory Standard 3.19, clauses 3.19.1⁽¹⁾⁽²⁾ to 3.19.9⁽¹⁾⁽²⁾

(1) Technical Handbook (Domestic).

(2) Technical Handbook (Non-Domestic).

Northern Ireland — Technical Booklet L, Sections 1 to 6.

11 Maintenance

As the product is confined within the wall cavity and has suitable durability (see section 12), maintenance is not required.

12 Durability



The product is unaffected by the normal conditions in a wall, and is durable, rot-proof, water resistant and sufficiently stable to remain effective as insulation for the life of the building.

Installation

13 General

13.1 The Certificate holder will provide on-site demonstrations on request, to ensure correct installation from the outset.

13.2 Adequate supervision of the installation should be maintained and the Certificate holder must have right of access to site to ensure correct installation.

13.3 It is recommended that the inner leaf be constructed ahead of the outer leaf, as the boards are fastened to the cavity face of the inner leaf. It is essential that the spacing of wall ties/clips allows one long edge of each board to be secured at a minimum of two points.

13.4 Vertical joints in the boards must be staggered and all joints tightly butted. Where protrusions occur in the cavity, the boards should be carefully cut to fit.

13.5 If installation of the boards is terminated below the highest level of the wall, the top edge of the insulation must be protected by a cavity tray and alternate perpend joints raked out, to provide adequate drainage of water from the tray.

13.6 Where required, door and window reveals should incorporate a suitable cavity barrier/closer. It is recommended that BBA-approved cavity closers are used.

14 Procedure

14.1 A section of the internal leaf is built in the conventional manner, with the first row of wall ties, at approximately 600 mm horizontal spacing, where the insulation is to begin. The wall ties should not be placed directly on the dpc. The first run of boards should commence at least 150 mm below the dpc level, to provide some edge insulation for the floor (see Figure 1).

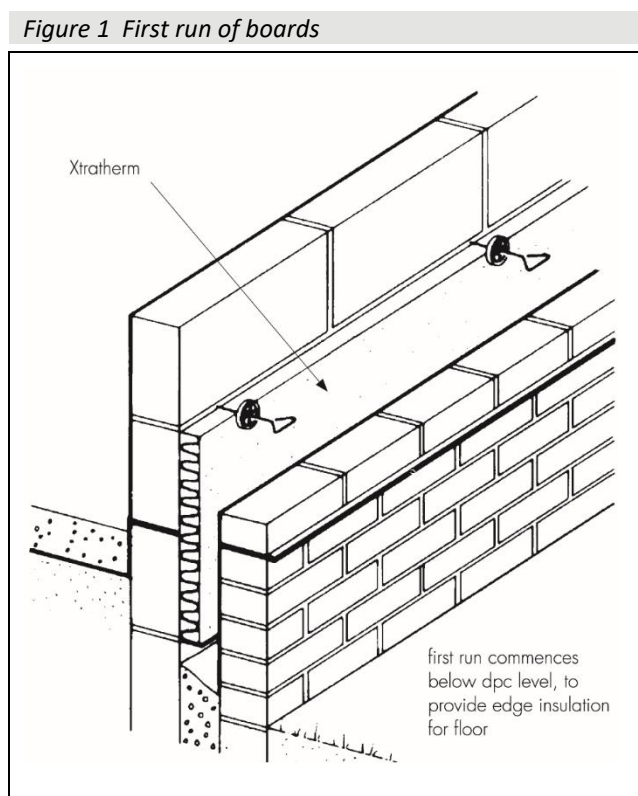

14.2 The internal leaf is then built up to a course above the next row of wall ties, which are placed at spacing of 450 mm vertically and not more than 900⁽¹⁾ mm horizontally (see BS EN 1996-1-2 : 2005). Excess mortar should be cleaned from the cavity face of the internal leaf.

(1) Where buildings need to comply with *NHBC Standards*, the spacing should be no more than 600 mm.

14.3 Boards are placed between the upper and lower wall ties, behind the retaining clips, to form a closely butt-jointed run. It is essential that all wall ties slope downwards towards the external leaf (see Figure 2), with the drip positioned halfway across the residual cavity width pointing downwards to shed water away from the internal leaf. Wall ties must not be placed at centres exceeding 900 mm to ensure that each board is secured at a minimum of three points. The first row of boards must not be in contact with the ground.

Figure 2 Detail of wall ties

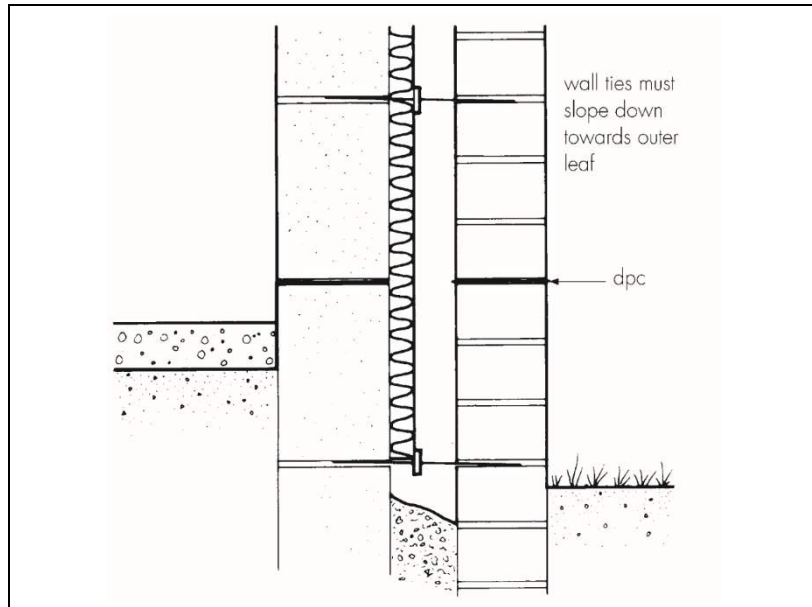

14.4 The external leaf is then built up to the level of the top of the boards.

14.5 Successive sections of wall, incorporating wall ties, are constructed and the boards installed as work proceeds up to the required height.

14.6 Additional ties may be required to satisfy the structural requirements of BS EN 845-1 : 2013, BS EN 1996-1-1 : 2005, BS EN 1996-2 : 2006 and BS EN 1996-3 : 2006, to ensure adequate retention of the product or cut pieces.

14.7 All boards should be butted together with vertical joints staggered. Insulation boards and wall ties should be staggered as construction proceeds and carried up to the highest level of the wall, except where protected by a cavity tray.

Mortar droppings

14.8 After each section of the leading leaf is built, excess mortar should be removed from the cavity face and mortar droppings cleaned from exposed edges of the installed board, before installation of the next run of boards. Use of a cavity board or a cavity batten will protect the installed board edges and help to keep the cavity clean as the following leaf is built (see Figures 3 and 4).

Figure 3 Use of cavity batten

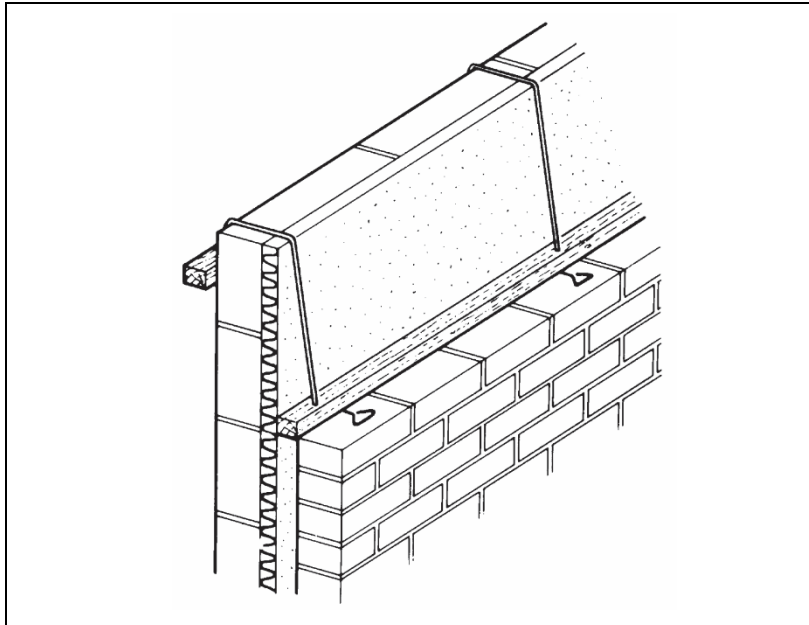
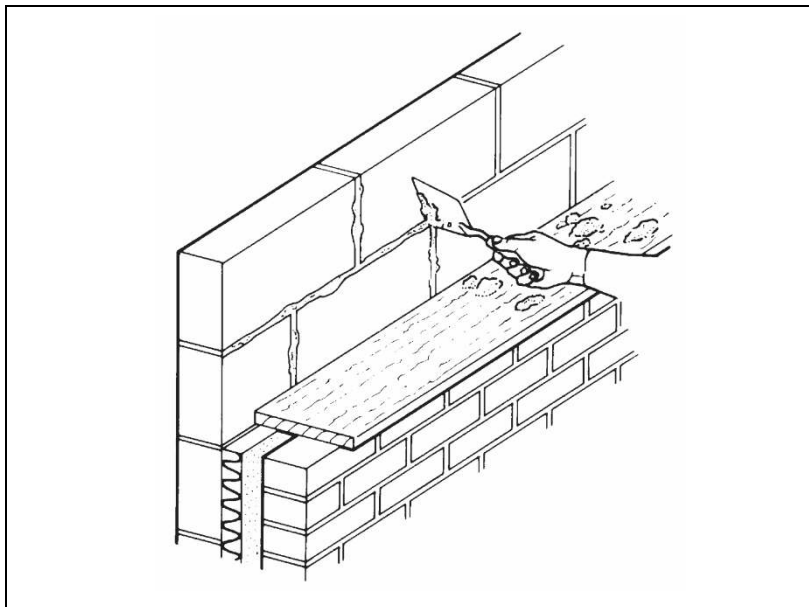

Figure 4 Use of cavity board



Wall openings

14.9 Where openings such as doors and windows are in close proximity, it is recommended that a continuous lintel or cavity tray is used. Individual lintels or cavity trays should have stopends and be adequately drained. Insulation boards should be cut to butt tightly against the cavity barrier/closer/dpc.

Cut pieces

14.10 Boards can be cut, using a sharp knife or fine-toothed saw, to fit around openings, eg around windows, doors and airbricks. It is essential that cut pieces completely fill the spaces for which they are intended and are adequately secured.

Protection

14.11 Exposed areas of board should always be covered at the end of a day's work or in driving rain.

14.12 All building involving the product, particularly interrupted work, must conform to BS EN 1996-2 : 2006, Sections 3.2 *Acceptance, handling and storage of materials* and 3.6 *Curing and protective procedures during execution*.

Technical Investigations

15 Tests

Results of tests were assessed to determine:

- thermal conductivity
- dimensional accuracy
- dimensional stability under specific temperature and humidity conditions
- compressive strength
- short-term water absorption
- long-term water absorption by partial immersion.

16 Investigations

16.1 A calculation was undertaken to confirm the declared thermal conductivity (λ_D).

16.2 A series of U value calculations were carried out.

16.3 A condensation risk analysis was carried out.

16.4 Existing data on toxicity, durability and properties in relation to fire were evaluated.

16.5 The manufacturing process was evaluated, including the methods adopted for quality control, and details were obtained of the quality and composition of the materials used.

Bibliography

- BS 5250 : 2011 + A1 : 2016 *Code of practice for control of condensation in buildings*
- BS 5618 : 1985 *Code of practice for thermal insulation of cavity walls (with masonry or concrete inner and outer leaves) by filling with urea-formaldehyde (UF) foam systems*
- BS 8000-3 : 2001 *Workmanship on building sites — Code of practice for masonry*
- BS EN 845-1 : 2013 + A1 : 2016 *Specification for ancillary components for masonry — Wall ties, tension straps, hangers and brackets*
- BS EN 1996-1-1 : 2005 + A1 : 2012 *Eurocode 6 Design of masonry structures — General rules for reinforced and unreinforced masonry structures*
- NA to BS EN 1996-1-1 : 2005 + A1 : 2012 *UK National Annex to Eurocode 6 — Design of masonry structures — General rules for reinforced and unreinforced masonry structures*
- BS EN 1996-1-2 : 2005 *Eurocode 6. Design of masonry structures — General rules — Structural fire design*
- NA to BS EN 1996-1-2 : 2005 *UK National Annex to Eurocode 6 — Design of masonry structures — General rules — Structural fire design*
- BS EN 1996-2 : 2006 *Eurocode 6 — Design of masonry structures — Design considerations, selection of materials and execution of masonry*
- NA to BS EN 1996-2 : 2006 *UK National Annex to Eurocode 6 — Design of masonry structures — Design considerations, selection of materials and execution of masonry*
- BS EN 1996-3 : 2006 *Eurocode 6 — Design of masonry structures — Simplified calculation methods for unreinforced masonry structures*
- NA + A1 : 2014 to BS EN 1996-3 : 2006 *UK National Annex to Eurocode 6 — Design of masonry structures — Simplified calculation methods for unreinforced masonry structures*
- BS EN 13166 : 2012 + A2 : 2016 *Thermal insulation products for buildings — Factory made phenolic foam (PF) products — Specification*
- BS EN 13501-1 : 2018 *Fire classification of construction products and building elements — Classification using test data from reaction to fire tests*
- BS EN 13914-1 : 2016 *Design, preparation and application of external rendering and internal plastering — External rendering*
- BS EN ISO 6946 : 2007 *Building components and building elements — Thermal resistance and thermal transmittance — Calculation method*
- BS EN ISO 9001 : 2015 *Quality management systems — Requirements*
- BS EN ISO 14001 : 2015 *Environmental management systems — Requirements with guidance for use*
- BRE Report BR 262 : 2002 *Thermal insulation: avoiding risks*
- BRE Report BR 443 : 2006 *Conventions for U-value calculations*

17 Conditions

17.1 This Certificate:

- relates only to the product/system that is named and described on the front page
- is issued only to the company, firm, organisation or person named on the front page – no other company, firm, organisation or person may hold or claim that this Certificate has been issued to them
- is valid only within the UK
- has to be read, considered and used as a whole document – it may be misleading and will be incomplete to be selective
- is copyright of the BBA
- is subject to English Law.

17.2 Publications, documents, specifications, legislation, regulations, standards and the like referenced in this Certificate are those that were current and/or deemed relevant by the BBA at the date of issue or reissue of this Certificate.

17.3 This Certificate will remain valid for an unlimited period provided that the product/system and its manufacture and/or fabrication, including all related and relevant parts and processes thereof:

- are maintained at or above the levels which have been assessed and found to be satisfactory by the BBA
- continue to be checked as and when deemed appropriate by the BBA under arrangements that it will determine
- are reviewed by the BBA as and when it considers appropriate.

17.4 The BBA has used due skill, care and diligence in preparing this Certificate, but no warranty is provided.

17.5 In issuing this Certificate the BBA is not responsible and is excluded from any liability to any company, firm, organisation or person, for any matters arising directly or indirectly from:

- the presence or absence of any patent, intellectual property or similar rights subsisting in the product/system or any other product/system
- the right of the Certificate holder to manufacture, supply, install, maintain or market the product/system
- actual installations of the product/system, including their nature, design, methods, performance, workmanship and maintenance
- any works and constructions in which the product/system is installed, including their nature, design, methods, performance, workmanship and maintenance
- any loss or damage, including personal injury, howsoever caused by the product/system, including its manufacture, supply, installation, use, maintenance and removal
- any claims by the manufacturer relating to CE marking.

17.6 Any information relating to the manufacture, supply, installation, use, maintenance and removal of this product/system which is contained or referred to in this Certificate is the minimum required to be met when the product/system is manufactured, supplied, installed, used, maintained and removed. It does not purport in any way to restate the requirements of the Health and Safety at Work etc. Act 1974, or of any other statutory, common law or other duty which may exist at the date of issue or reissue of this Certificate; nor is conformity with such information to be taken as satisfying the requirements of the 1974 Act or of any statutory, common law or other duty of care.