



VERSAROC

Fibre Cement Sheathing Board



VERSAROC

MPA1 fibre cement sheathing board

A fibre cement board comprising ordinary Portland cement with inorganic reinforcing fibres. Ideal for exterior sheathing of SFS frames due to high durability and non-combustibility.



- CE marked according to EN 12467:2012 + A1:2016
- Reaction to fire: A1 non-combustible according to EN 13501-1:2007 + A1:2009 ensuring minimal fire risk
- Contains no hazardous volatiles, is asbestos free and its process dust is none aggressive
- Light grey in colour, relatively smooth to one side with textured reverse
- Highly moisture tolerant and has achieved category A performance to EN 12467:2012 + A1:2016

VERSAROC

MPA1 fibre cement sheathing board

- Versaroc MPA1 has exceptional mechanical performance
- Helps improve the airtightness of building envelopes when sealed at joints
- Relative high density for excellent acoustic performance
- Available in either 9mm or 12mm in standard sheet size 2400 x 1200mm
- Bespoke sizes available to suit your system requirements
- A wide range of systems may be applied over Versaroc MPA1 such as:
 - Approved ETICS systems
 - Terracotta cladding systems
 - High performance cladding systems
 - Traditional brick coursework

VERSAROC Technical data

Parameter	Value	Tolerance / test standard
Sheet length	2400 mm	+/-3mm
Sheet width	1200 mm	+/-3mm
Sheet thickness	9 or 12 mm	EN 12467
Straightness of edges	< 0.3 %	EN 12467
Squareness	2 mm/m	EN 12467
Dry density	1300 +/- 50 kg	EN 12467
Approx. weight per sheet - 9mm - 12mm	34 kg 45 kg	N/A
Reaction to fire	A1-Non combustible	EN 13501-1
MOR - Modulus of Rupture / Bending strength in wet conditions	> 9 MPa	EN 12467 - class 2
MOE - Modulus of Elasticity	> 3 kN/ mm ²	N/A
Moisture movement in thickness	< 10 %	EN 12467
Water impermeability	No droplets	EN 12467
Inter lamina bond strength (MPa)	> 0.8	N/A
Ex works moisture content (%)	TBC	N/A
Maximum moisture content (increase in mass)	< 32 %	EN 12467 compliant

VERSAROC Optional wall finishes

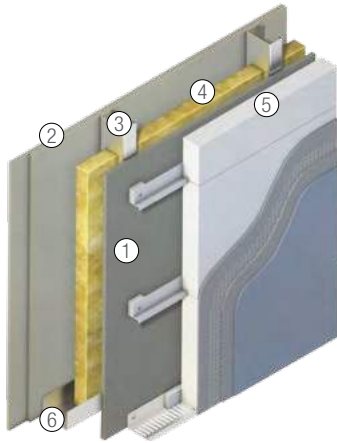

Externally Insulated Render System

The sheathing board is fixed to SFS and over clad with thermal insulation. This is then rendered to provide a decorative finish.

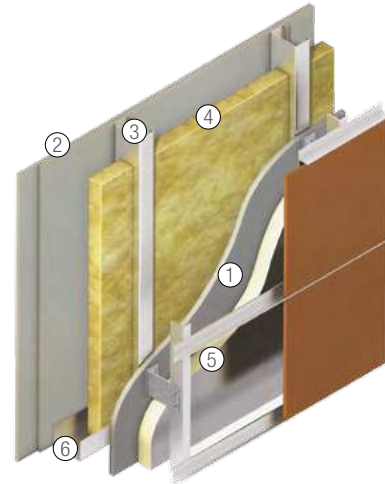

Ventilated Rainscreen

The sheathing board is fixed to SFS with helping hand brackets fixed to the studs through the sheathing board. The rainscreen cladding system is then installed to include a rail system. Such systems may incorporate EWI as approved.

Key: ① VERSAROC ② Dry Lining ③ SFS ④ Internal Insulation ⑤ External Insulation ⑥ Base track

VERSAROC Optional wall finishes

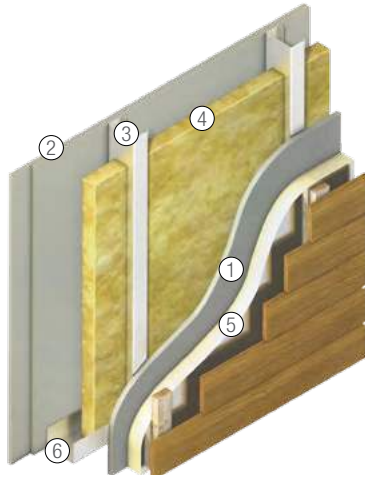

Timber Cladding

The sheathing board is fixed to SFS with rigid insulation typically fixed to the framing through the sheathing board.

Timber cladding is then installed on to counter battens.

WeatherClad® Low maintenance shiplap cladding is available. Please contact Euroform for details.

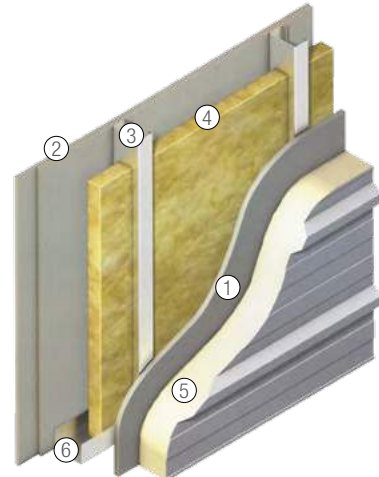

Composite Panels

The sheathing board is fixed to SFS and the composite panel is fixed to the steel frame through the sheathing board.

Key: ① VERSAROC ② Dry Lining ③ SFS ④ Internal Insulation ⑤ External Insulation ⑥ Base track

Working with **VERSAROC** Delivery and storage

- Boards should be received in a dry state with pallets protected from weather with plastic sheeting or similar.
- Boards should be stored on flat, dry pallets elevated on skids/battens sufficiently from ground level to prevent board wetting.
- If boards are stored on site for a long period of time they should be kept under cover/ indoors if possible.

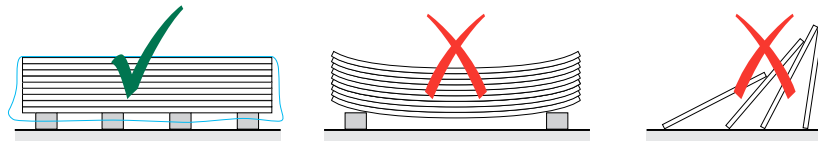

- When manually moving boards they should be carried in a vertical orientation.

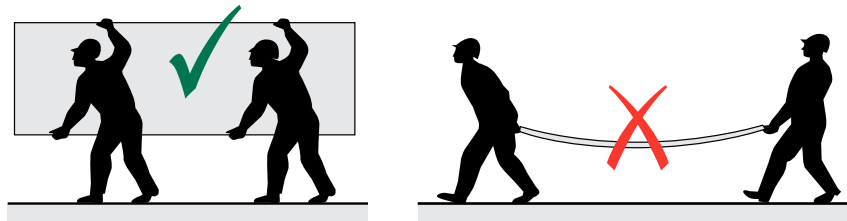

Working with **VERSAROC**



Sawing

Equipment:

- Cross cut hand saws for thicknesses up to 12mm
- Jigsaw for thicknesses up to 12mm and small work
- Portable circular saw
- Fixed saw for dimensioning (vertical or horizontal)

Type of blade:

- Alternative or trapezoidal teeth
- Chart shows number of revolutions and number of teeth (Z)

Diameter (mm)	250	300	350	400
Panel thickness up to 12mm	Z=48	Z=60	Z=72	Z=72
Panel thickness exceeding 12mm	Z=36	Z=48	Z=54	Z=60
Number of revolutions (rpm)	3000/ 4500	3000	3000	3000/ 1500

VERSAROC

Mounting and fixing

The following table is a guide to fixing distances for most common applications.

Board Thickness	Fixing Distance Centres (mm)			
9 - 12 mm	A	A1	B1	C1
	40	15	300	600

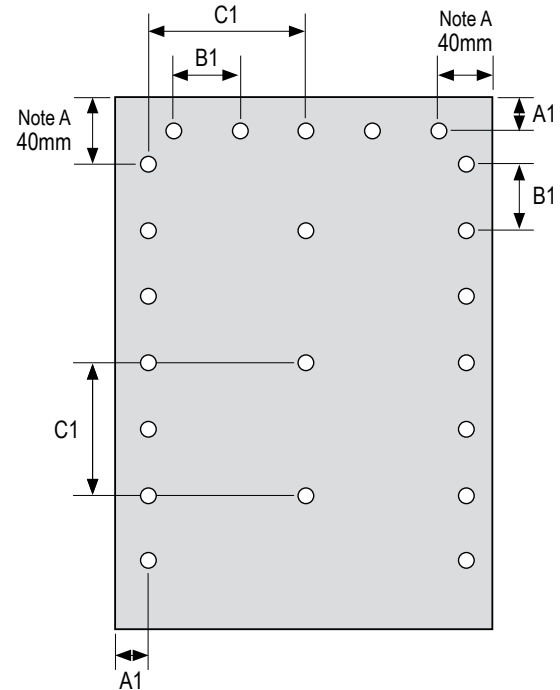

Note A: The first fixing in from the corner for both horizontal and vertical fixing must be 40mm in from the edge.

VERSAROC

Board arrangement

Euroform recommends that Versaroc is installed in brick bond fashion as per the diagram.

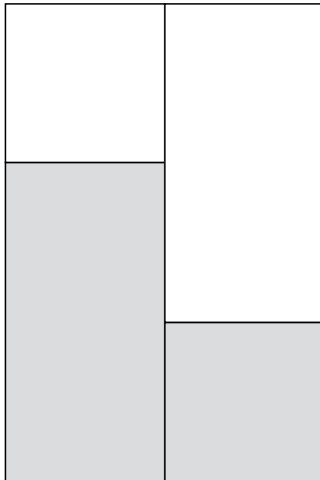

NOTE:

- 4 way joints are not recommended
- Minimum board width should not be less than 600mm

Expansion/Movement Joints

- Versaroc can be affected by slight dimensional changes according to variation in relative humidity
- Leave a 3 - 6mm gap at all joints
- Board edges will not degrade with exposure to exterior conditions however generally a joint filler/cover is recommended
- Joints can be filled with Versaseal Intumescent Joint Compound or approved tapes

Fixings

Steel Substrate	Board Thickness	Screw Type
1.0 - 2.0mm	9 - 12mm	EMF1 4.8x45mm
2.0 - 3.0mm	9 - 12mm	EMF2 4.8x35mm

VERSAROC

Water proofing

Where boards are used below and within 150mm of DPC level a compatible waterproofing membrane should be applied.

Compatible EPDM membranes should be used around other areas at risk of water ingress e.g. at window openings.

Use of breather membranes

A suitable breather membrane should be used when using Versaroc as a sheathing board. The board should not be relied on to prevent moisture ingress.

Screw withdrawal performance

- Versaroc may be able to contribute to the securing of external wall insulation.
- Screw withdrawal (pull-out) tests should be carried out on site by a qualified consultant to determine board performance.
- Number and type of insulation fixings should be determined by wind loading assessment to be carried out by an appropriately qualified engineer.
- Any rails/profiles to be used to support cladding etc. should be fixed back to pick up on supporting SFS studs.



T 01925 860999
E info@euroform.co.uk
W www.euroform.co.uk

Euroform is part of



www.PerformanceTechnologyGroup.com