

## HADLEY 70mm C STUDS

Hadley C Studs are cold-rolled steel studs used as part of a Hadley Drylining System to create non-loadbearing internal partitions.

Manufactured in accordance with EN 14195:2005



Scan QR code for Hadley Drylining *Golden Thread* Documents: Technical Datasheet, Material Safety Datasheet, Declaration of Performance (DoP), O&M Manual and more...

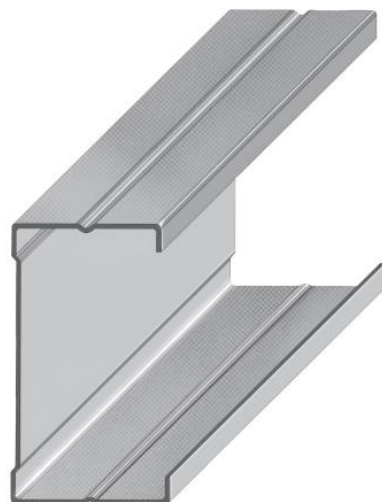

### Product Information

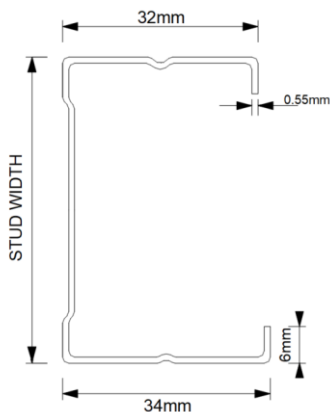

<b>Width</b>	70mm
<b>Flange</b>	32mm/34mm
<b>Gauge</b>	0.55mm
<b>Lengths</b>	2.4m / 2.7m / 3.0m / 3.6m / 4.2m
<b>Pack Quantities</b>	10 / 50 / 300

**REACTION TO FIRE:**  
A1

**YIELD STRENGTH:**  
210 (N/mm<sup>2</sup>)

**SERVICE CUT OUTS:**  
80mm x 30mm @ 600mm Centres

**SYSTEM PERFORMANCE INFORMATION:**  
To be installed as a part of a complete Hadley Drywall system to achieve both Fire and Acoustic performance. To understand more about our fully warranted and tested solutions, please contact our Hadley Technical Support Team.

**STORAGE & HANDLING:**

When installing Hadley components please ensure full PPE is used and the site is practicing a safe working environment alongside industry standards.

**DISPOSAL:**

Hadley Metal is fully recyclable.

**SYSTEMS USED:**

- HadleySOLO – Single Stud System
- HadleyDUO – Twin Frame I Stud System (\*used only at abutments)
- HadleyBRACE – Braced Twin Frame System
- HadleyHUSH – Single Stud System using Resilient Bars
- HadleySTAGGER – Staggered Stud System (\*used only at abutments)
- HadleyLINE- Independent I Stud Lining System (\*used only at abutments)